

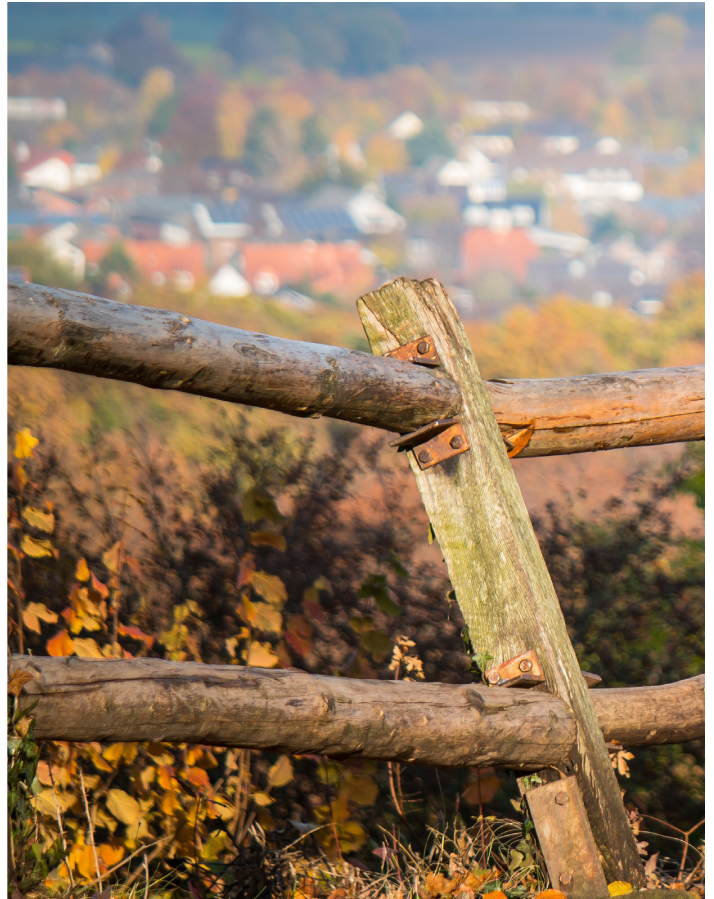

THE UNIVERSITY OF
SYDNEY

**The Henry
Halloran Trust**

A Blue-sky
Report



Intersections of Stigma, Social Capital & Community Engagement in the Suburbs: A Social Network Analysis

*Kathleen Flanagan,
Julia Verdouw &
Daphne Habibis*
University of Tasmania

Report 15HT01
Blue Sky Report 2017

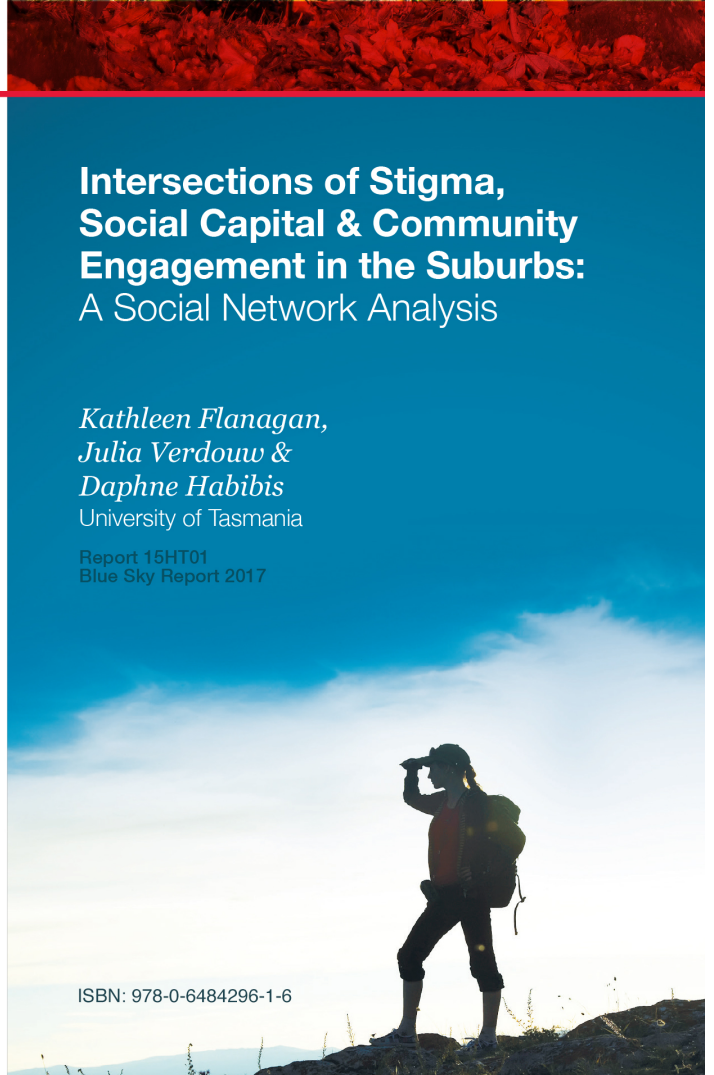

ISBN: 978-0-6484296-1-6

Correspondence

Dr Kathleen Flanagan
Housing and Community Research Unit
University of Tasmania

Ph.: + 61 3622 67487

E: Kathleen.flanagan@utas.edu.au

Table of Contents

Executive Summary	3
Introduction	5
Stigma and place	5
Social capital and community ties	7
Research questions	9
Methodology	10
Research context	10
Social network analysis	11
Participant profile	16
Findings	18
Neighbourhood stigma	18
Neighbourhood social connections	28
Connections with services	47
Limitations	50
Discussion	51
Conclusion	53
References	55
Appendix 1	60
SNA measures used in report	60
Appendix 2	62
Expanded tables	62

Executive Summary

The issue of how to build community engagement and promote pathways to economic and social inclusion for the most excluded social groups is one of the most vexed policy questions. Place-based stigma is frequently named as a barrier for the successful implementation of community development strategies designed to address these (Warr 2005a), with the layers of stigma within and across communities often unacknowledged. The literature suggests that the stigmatisation that affects identifiably 'disadvantaged' places is reproduced on a smaller scale internally. That is, within an area labelled by outsiders as 'bad', insiders may project this reputation onto certain streets or groups of people or manifestations of behaviour as a way of disassociating themselves from the tainted reputation. Therefore, certain members of the community are subjected to multiple layers of stigma, and, this may present a barrier to their involvement in community development activities premised on the idea of a more homogenous community.

To examine this issue this project takes an innovative approach designed to identify how place-based stigma creates division and social exclusion within the neighbourhood itself. It aims to map social and relational networks in order to build on our understanding of the processes of stigma (re)production and mitigation. To this end, the project mapped social networks and relationships within sub-sections of a disadvantaged urban Tasmanian community. This relational approach to understanding people and place has provided a knowledge base about intra-neighbourhood manifestations of stigma and reputation.

Touraine (2000) argues that the process of stigmatisation can cause communities to become introverted, effectively functioning as a process of ghettoisation. Our research highlights that this introversion is not limited to reactions to perceptions of a 'bad area' from outside, but continues, in a kind of 'micro-process of introversion', into the topography of the area itself — an 'intra-territorial stigmatisation'. While our data supports Warr's (2005a, p. 8) point that the 'unsympathetic attitudes and actions of outsiders' add to the challenges of living in a stigmatised neighbourhood, it also suggests that intra-neighbourhood stigma perpetuates the social and spatial divisions that already exist because of external stigmatisation.

This is a form of 'othering' (Crisp 2013) well recognised in stigmatisation literature per se but not understood as well in relation to intra-territorial or intra-neighbourhood stigma. Further, unlike other studies, which attribute intra-neighbourhood stigma to situations where middle class residents in an area resent and reject social housing tenants or other low income groups, our social network analysis methodology revealed that stigma is correlated less with socio-economic differences and more to the number and type of social ties within the neighbourhood. Relative intra-neighbourhood isolation and internal density contributes to a self-perpetuation of neighbourhood divisions, providing fewer reasons to engage and greater reason to internalise the Chinese whispers and dark urban legends relegating one place as a scapegoat for the rest. In this sense '...stigma is more than simply the presence of a negative group stereotype: it is an active, corrosive process that undermines relations between communities' (Stevenson et al., 2014: 465).

Thus, the study shows both empirically and specifically that social space *is* 'roughly superimposed' (Bourdieu 1999, p. 125) upon physical space, and this results in intricate entanglements of power (Sharp et al. 2000). This knowledge provides a unique lens for understanding disadvantaged urban places, particularly when laying the foundation for community development strategies to address disadvantage and stigma. In particular, we stress the need for supporting the identification of entry and re-entry points for building relationships across and between the micro-territories that are most and least at risk of internal stigmatisation. Without them for example, community development strategies may (unintentionally) continue to deepen internal stigmatisation by continuing to build relational capital *within* rather than *between* the spaces where representational struggles are fought (Harvey 1996). Strategies can thus be used to repair spatial and relational fragmentation by building collaborative relationships across individuals and organisations, particularly focusing on those who have become isolated or 'districts of relegation' (Wacquant 2016) within their wider urban territory. Addressing these internal divisions will deepen our understanding of how everyday social practices and (symbolic) performances converge with spatial geography and topography to heal social divides.

Introduction

The issue of how to build community engagement and promote pathways to economic and social inclusion for the most excluded social groups is one of the most vexed policy questions. It is especially relevant to Tasmania because of the state's high rates of social disadvantage, low rates of economic investment and the hollowing out of regional communities as a result of global economic trends. The topic sits within the broader policy issue of community development and is closely allied to local, national and international concerns with improving economic participation and building healthy and sustainable communities.

Although place-based stigma is frequently named as a barrier for the successful implementation of community development strategies (Warr 2005a), the layers of stigma within communities and the way particular individuals, groups or areas within an already stigmatised community can be further marginalised, often pass unacknowledged. Intra-neighbourhood stigma attaches most to people with complex, interrelated issues, including drug and alcohol problems, disability, mental illness, violence and abuse and unemployment. Some may also exhibit demanding or anti-social behaviour and resistance to change (Warr 2005b). The barriers to engagement with disadvantaged communities are well-recognised (Wood, Randolph & Judd 2002). For those stigmatised within the community, these barriers are intensified (Hinton 2010). This project addresses this concern through an innovative approach designed to identify how place-based stigma creates division and social exclusion within the neighbourhood itself. The project aims to identify how networks operate as enablers and constraints through relationships of power, trust, conflict and collaboration.

One of the limitations of existing efforts to increase community engagement arises from the unintended effect of 'benevolent othering' where efforts to promote acceptance reproduce stigma because they gloss over differences and conflicts and fail to acknowledge power imbalances (Grey 2008). Strength based approaches to community development have been similarly criticised (Mathie & Cunningham 2003). Social network analysis offers an innovative way to tackle these problems (Ennis & West 2010). It conceptualises social structure as a network of relationships of trust, referral or exchange between people, organisations and other entities. It is a research methodology and an orientation which informs practice, but to date has had limited application within housing, urban and community research. By mapping community relationships as well as assets, strengths or capacities researchers can incorporate information about inequitable levels of access to resources and relative levels of power within the network, and identify points of entry based on 'careful understanding and engagement' (Grey 2008) rather than on externalising and distancing, as occurs in benevolent othering.

Stigma and place

Goffman (1963:i,3) defined 'stigma' as humans limiting or reducing a person from a 'whole and usual person to a tainted, discounted one' in a kind of 'discrediting' because of an attribute that makes them different from others and 'disqualifies' them from being fully socially accepted. Poverty, Warr (2005b:199) notes, is 'compellingly associated with being reliant on state welfare [and] diminished capacity for economic reciprocity is concomitant with low social value and becomes a discredited attribute'.

It has been noted that Goffman does not identify territory, or place, as one of the discrediting attributes that might 'disqualify' individuals from acceptance by others (Wacquant 2007:67). Yet stigma, experienced as a negative labelling, is often directed to contexts where socio-economic disadvantage is prevalent, concentrating in 'discredited' neighbourhoods (Warr 2005a, 2005b), where participation and exclusion are closely connected with 'spatial relationship and the meaning of place' (McDonald 1999:45). Thus a newer phenomenon evident in literature around stigmatisation is what Wacquant and colleagues (2014) call 'neighbourhood taint'. Stigma around geographical place is also referred to as spatial or territorial stigma (Warr 2005a; Wacquant 2007), or even theorised as 'dumping grounds' (Cheshire & Zappia 2015). Territorial stigma refers, Wacquant notes, to 'penalised spaces' that are not disseminated throughout suburbs but territorially concentrated in areas perceived by both outsiders and insiders as a 'blemish of place' (Wacquant 2007:67).

The neighbourhood in this study is a geographically isolated suburban neighbourhood with a relatively high proportion of social housing tenants – some 42% of all the properties (dwellings and vacant land) in the area are social housing (DHHS 2010). Specifically, the vulnerability of communities with concentrations of public and community housing to stigmatisation also been regularly discussed in the literature (Palmer et al. 2004; Warr 2005a, 2005b; Wacquant 2007; Atkinson & Jacobs 2008; Jacobs et al. 2011; Jacobs & Flanagan 2013). Waxman (1983) has noted that one of the consequences of such vulnerability is the hardening of existing social and economic divisions. Additionally, residents in neighbourhoods relegated to marginality through territorial stigmatisation are affected at the subjective level of social ties and by the state policies that shape them (Wacquant 2014:1700-01). These issues are further aggravated by the residualisation of social housing to households in greatest need and greater concentration of social and low-cost affordable private rental in particular geographic areas.

Wacquant and colleagues' conceptualisation of 'territorial stigmatisation' provides a useful conceptualisation of spatial or geographically located stigma. Including five characteristics, it is first a stigma tied closely with poverty, regional ethnic minorities, deteriorated housing, immoral behaviours, and urban crime. Second, there is a 'nationalised' and 'democratised' element to the locations in the sense that they have become recognised beyond their immediate locations as tainted and reviled places, both in social discourse (e.g. journalism and politics) and in everyday conversations. Third, the neighbourhoods conjure images of social denigration and disorganisation (e.g. 'ghetto'), which is related to the fourth element which is the use of selective and fictionalised or sensationalist language to account for their differences. Finally, these territorial spaces evoke dark emotions and penal responses to urban marginality (2014: 1273-5).

The neighbourhood of focus in this study is located in the local government area of Devingdale¹, and is often conceptualised in terms similar to those Wacquant describes. Substantively, Devingdale itself is identified in a recent national study (DoTe 2015) on disadvantage as one of the most disadvantaged local government areas in Tasmania, its position having deteriorated by their measures of disadvantage since 2007. This report highlights a number of characteristics of disadvantage in the area, including disengaged young adults, unemployment and low family income, higher rates of resident contact with the justice system, and higher levels of disability. As noted above, the particular study neighbourhood has a high proportion of social housing tenancies in the area relative to other localities, and it also has almost double the number of

¹ Pseudonym.

residents in housing stress (17.5%) than Tasmanians per se (9.5%) (ABS 2013). In addition, the area is known in the surrounding city and within Tasmania as an area with a poor reputation, embedded in the pejorative language found in urban slang, social networking sites, media threads and local narrative as ‘the wrong side of the tracks’ and a place to avoid at all costs. Recent high profile media cases pertaining to violent crime (whose perpetrators reside in the study area) also subtly disseminate the message that these behaviours are extrapolated across the neighbourhood. The intractable nature of the stigma associated with the neighbourhood highlights that unfortunately it does bear the conceptual weight of Wacquant’s ‘territorial stigmatisation’.

While most literature focuses on the issue of external stigma, a small number of papers point to the existence of intra-neighbourhood stigma (Palmer et al. 2004; Arthurson 2005), or different scales of stigma *within* a neighbourhood (Arthurson 2013). Intra-neighbourhood stigma can be an unintended outcome of social mix strategies such as the ‘pepper-potting’ of social housing into wealthier neighbourhoods. For example, stigma in mixed tenure neighbourhoods has been found to be ‘localised and targeted at individual groups and housing tenures’ aimed primarily at those in lower socioeconomic strata and social housing tenures (Arthurson 2013: 16). Strategies used by middle-class residents to manage stigma in disadvantaged neighbourhoods include ‘non-belonging’ or disaffiliating practically and discursively (Pinkster 2014).

This study analyses both territorial or spatial stigma and its counter-part, inter-neighbourhood stigma, in the context of a disadvantaged neighbourhood in Tasmania. Although this location is considered by outsiders and policy-makers as a cohesive ‘neighbourhood’, geographically it consists of five distinct (but small) suburban areas, providing a unique context for the study of intra-neighbourhood stigma. Four of these areas are included in the study (Forest Bay, Park Rise, Woodland Grove and Grass Hill²), each having different but generally high proportions of social housing, and all subsumed within the stigmatisation that attaches to the area as a whole. The fifth area is the original regional community that pre-dated the establishment of social housing in the area. Earlier successful neighbourhood renewal initiatives in the four study areas have assisted in ameliorating negative external attitudes and in building social pride (Jacobs, Arthurson & Randolph 2005), however deep levels of stigmatisation persist.

Social capital and community ties

Stigma is rarely discussed without reference to the social challenges attributed to its effects. Among other things, these effects include warped social relations and an undermined capacity for collective action (Wacquant 2013) and limited capacity for reciprocity, leading to the outcome of being afforded little social value and being consistently unrecognised (in economic terms) for social contributions (Warr 2005b:305). Conversely, it has been long suggested that for disadvantaged people, social capital is one of the most significant protections against vulnerability in the absence of adequate material conditions (Woolcock & Narayan 2000). This section will provide a brief outline of key findings in current relevant social capital literature related in particular to disadvantaged neighbourhoods.

Bourdieu’s (1986:248) definition of social capital is the ‘aggregate of the actual or potential resources which are linked to possession of a durable network of more or less institutionalized relationships of mutual acquaintance or recognition’. While Bourdieu’s definition is theoretically

² Pseudonyms.

refined, Agampodi and colleagues note that Putnam and colleagues' (1993) definition is more widely used: 'features of social organization, such as trust, norms and networks that can improve the efficiency of society by facilitating coordinated actions'. Intrinsic to Putnam's definition is the assumption that social capital is inherently good for community, based in the popularised notion (e.g. in policy) that encouraging engagement in formal associations (Putnam et al. 1993) and informal social networks (Putnam 2000) is the foundation to healthy and vital community. The evident decline in social capital and dwindling of social relationships is consequently viewed as corroding urban communities. For example, in the general population the decreased ability to trust has been shown to have a significant association with declining self-rated health (Giordano & Lindstrom 2009). This view is not without critics. Studies cite the overstated nature of the loss of community bonds, arguing instead that there is continued evidence of strong and localised social capital in disadvantaged communities, found in patterns of everyday support, kinship relations and extended associational networks and belonging to place (e.g. see Warr 2005; Watt 2006; Robertson et. al 2008).

Crisp (2013:327) addresses the competing explanations of social capital in urban places by outlining two key frameworks through which contemporary social capital theories can be explained. The first he names as 'community undermined'. This framework (see Amin 2005; Lupton 2003; Olagnero et al. 2005; or Watt 2006) explains social capital within the context of Putman's (1993 and 2000) 'loss' theories, arguing that social relations are eroding due to a range of economic and social factors across complex social and spatial scales. With a generally more nuanced interpretation of this decline than Putnam however, they argue that social connections might or would improve in the context of ameliorated material conditions. The second framework Crisp names 'community unbound' whose proponents (see Gosling 2008; Leonard 2004; Warr 2005; Blokland 2003) argue similarly that social relations in disadvantaged neighbourhoods are indeed eroding. However, rather than problematising this as certain urban demise, it is argued that this shift represents a 'privatization of community' (Blokland 2003), where residents are choosing more carefully to spend time with closer family and intimate friends rather than with general acquaintances and neighbours, and further, that that social ties are increasingly becoming disembedded from place of residence. Crisp (2013: 336) helpfully argues that together these frameworks allow for a pluralistic approach to the study of disadvantaged neighbourhoods because together they can account for the inevitable diversity of social dynamics across spatially varied urban regions.

Social capital itself has multiple conceptual dimensions. First, social capital is usually conceptualised as either 'structural' (externally observable social interactions), or 'cognitive' (the norms, values and beliefs of people which affect their social participation) – that is, as either what people 'do' or what they 'feel' (Agampodi et al.2015:106). Further, social capital is often constructed in terms of 'bonding' and 'bridging' capital (see Woolcock & Narayan 2000, attributed to Gittel& Vidal 1998; De Silva et. al 2007). Bonding capital is described as social cohesion within a group structure, and 'bridging' social capital as that which links different or diverse community groups. The former is also likened to horizontally-based constructs of social capital, linking similarly socially positioned individuals, and the latter as vertically based, consisting in the intersection between different levels (community, associations, or local/state government) of society (Agampodi et al. 2015). Other less utilised studies draw on further dimensions to conceptualise social relationships, including the observation of above-mentioned measures along a continuum from static to dynamic behaviours (Kikuchi & Coleman 2012).

Research questions

The theoretical foundations of this study are found in concepts of stigma (in the context of residential neighbourhood disadvantage) and social capital. Therefore the question guiding the research is:

How does intra-neighbourhood stigmatisation manifest itself through physical and social topographies and their informal and formal social and economic networks?

The following subsidiary questions provide a more detailed focus:

1. To what extent are there distinctions in the nature of social capital between more and less stigmatised locations within the neighbourhood?
2. Do these distinctions include differences in the quantity and quality of external social and economic networks?
3. How does stigmatisation impact on housing stability?
4. Is there a relationship between stigmatisation and patterns of service access and volunteering?

In undertaking this research, we sought to expressly include the more excluded groups in the community, because they are consistently missing from community engagement programs, even though the aim of such programs is often to attract services and investment that will enable the community to better respond to its most marginalised residents. To achieve its objectives, the project pioneered the use of social network analysis, which to date has had limited application in community development research. Our methodology extends beyond approaches to social asset mapping in communities (e.g. University of Tasmania Regional Urban Studies Laboratory 2016, forthcoming) by using social network analysis to incorporate information about the relationships that constrain or enable community engagement, including the distribution of power and access and modes of exclusion and marginalisation.

Methodology

Research context

The focus on the interrelationship between stigma, place and social capital requires a methodological approach directed at mapping existing social relationships between people and community organisations. In the last few years the Tasmanian Government has transferred management of public housing in broadacre estates to non-government organisations under the banner of 'Better Housing Futures'. The transfer has involved four portfolios in distinct geographical regions. The estates where our research was undertaken were transferred in mid-2014.

It was important and necessary that as researchers we had some proximity to the neighbourhood both in terms of understanding the social and physical environment through a local and respected gatekeeper as a link to relevant local service providers and participants, and as a means of investing back into the community through having our findings translated directly into action through community development. Consequently, the research was undertaken in partnership with a community housing provider, one of the 'Better Housing Futures' landlords. This relationship was vital in providing us with knowledge, information, contacts, assistance with the survey administration, and the proximity and means to engage in community development initiatives arising directly from the research. Significantly, a substantial portion of the organisation's community development worker's time was made available in-kind to work on the project, assisting particularly with recruitment and data collection. Her local networks and knowledge, and her capacity to build rapport with people in the community, were invaluable to the process. The relationship was also beneficial to the organisation, because one of the requirements placed on the new landlords is the development of a community engagement strategy, and our research was able to generate robust evidence to support this process.

The site chosen for the research was originally constructed as broadacre public housing by the Tasmanian Housing Department in the 1970s. It was built on the urban fringe of Hobart, and the surrounding area remains comparatively undeveloped today. As it exists now, the whole estate is cut in half by a major highway, and then each half is further bisected by a river. This divides the estate effectively into four distinct sections, and it is further divided conceptually because these sections have their own name. For the purposes of our research, we will use the term 'neighbourhood' to refer to the four areas collectively, the pseudonyms of Forest Bay (FB), Park Rise (PR), Woodland Grove (WG) and Grass Hill (GH) to refer to each section individually, and the pseudonym 'Devingdale' to refer to the nearby town which gives its name to the municipality in which the estate was built. The word 'area' is applied only in relation to Forest Bay, Park Rise, Woodland Grove and Grass Hill, and the word 'location' is used generically to refer to a place.

Shortly after construction on the estate commenced, the then Tasmanian Government made two significant policy changes (Flanagan 2015b). The first was to phase out its previous policy of allocating homes on a rent to purchase basis as the first option, with tenancy arrangements preserved for those occupants whose incomes were such that they required a rental rebate to be provided. The second was to cease building broadacre housing and instead move to a policy of only infill development in already established areas. These changes had some significant effects on the estate where we undertook our research. First, the tenure patterns are not even across the estate. In Forest Bay and Park Rise, which were among the first stages in the development, many

of the new occupants started out as prospective home-owners. New occupants in Woodland Grove and Grass Hill were more likely to begin life in the area as tenants. Secondly, the original concept plan for the estate had identified it as a 'new town' — it was intended that it would grow into a major urban centre that would be of sufficient size to attract self-sustaining commercial investment and employment opportunities. This initial concept informed many aspects of the estate's development, including site selection and layout; the size of the new development would, it was thought, counteract its relative geographical isolation from the rest of Hobart. But the estate was not finished when the Department pulled out, with Woodland Grove and Grass Hill in particular remaining significantly underdeveloped compared to what had been intended (see Flanagan 2015a). These policy decisions, along with the wider shifts in public housing policy that have led to a residualised, stigmatised and under-funded system overall, mean that the estate has become one of the most disadvantaged places in Tasmania.

Social network analysis

The goal of the research, to examine the relationship between stigma, place and social capital, requires a methodological approach that provides insights into the relational ties between local people, their formal and informal connections and local and regional organisations. Social network analysis (SNA) is a systematic tool primarily used to better understand basic social structures by analysing the networks constituted by individual actors, things within the network and the relationships that connect them (Martin 1967). In SNA, social structures are conceptualised as containing two key elements: actors (or nodes) and ties (relationships). A social structure therefore is a network. The assumption underpinning SNA is that the analysis of relational ties will reveal patterns that will add to our understanding of the network as a whole (Burcher & Whelan 2015; Ennis & West 2010; Abbasi et al. 2014). Following from Waltzer (1990), networks are often thought of in terms of 'civil society'. However, social capital is not exclusively confined to voluntary associations, argues Norton (1997), who suggests SNA can be used to identify three types of social networks between people: community-type, clustered, and isolated social networks. He argues that 'community-type' are networks in which there is a great deal of cross-over, such that people will encounter each other in multiple spheres of their lives. Clustered networks are based around discrete spheres of life, each with its own differentiated group of people. Finally, isolated networks comprise just a few social ties, mainly immediate family and perhaps a few close friends. SNA is therefore a means to evaluate not only relationship ties but the particular contexts in which they are embedded that are (or are not) conducive to the creation of social capital (Burbidge 1998). This is particularly salient in the current study.

There are two main approaches to network analysis. One is a complete or whole network analysis, which observes every actor in a defined (or bounded) population, such as all the staff members in an organisation. Another is ego-net or ego-centric analysis, an approach that focuses on particular social actors (egos) in a specific population, in order to explore their social ties. The relationships between the members of the ego's network (known as alters) may also be explored. For example, researchers might use this method by snowball sampling to track hard to find populations, or to provide a sample of what actual networks in a chosen context may look like. In this study, we used an ego-net approach. The purpose of an ego-net approach is to describe the ego relationships in terms of the number, characteristics, intensity, direction, density (to name a few examples) of the ties egos have with alters (Krebs & Valdis 2013). This builds a picture of the way in which people are situated within their relationships. In this way, we are able to provide a

picture of the possible structures (and characteristics of those relationship structures) of personal relational networks in our study area.

Sampling and recruiting strategy

The population of the study neighbourhood is 7490 (ABS 2013) and too large for whole network analysis. In the context of limited time and resources, our goal to focus on social relationships in the context of stigma and housing instability informed our decision to allocate particular (pre-defined) streets or localities within the four locations of Forest Bay, Park Rise, Woodland Grove and Grass Hill as areas from which to sample for participants. This is an unusual sampling method in the context of SNA, as we did not want to snowball *into* a particular population, but rather sought to understand social ties occurring in the particular context of housing instability and stigma *across* the neighbourhood. However, the method is not without precedent; a 1967 study in Adelaide by Jean Martin investigated kinship by studying families from three different suburbs in particular (pre-chosen) localities with specific educational class backgrounds, and McAllister and Fischer's 1978 study similarly involved selecting participants from four neighbourhoods in one city area (an inner city district, a working-class suburb, a planned suburban community and a very affluent suburb).

With residents in the neighbourhood of Forest Bay, Park Rise, Woodland Grove and Grass Hill as our focus population, we collaborated with key local service providers involved in provision of regular (almost daily) services to the community at the household level: the community police representative for the neighbourhood, the community housing provider responsible for the social housing portfolio, the manager of the community neighbourhood house network (which comprises two houses, located respectively in Forest Bay and Grass Hill) and the child and family nursing service. They each identified locations within each of the four areas of the neighbourhood which they perceived to be either the least stigmatised or the most stigmatised, particularly in terms of housing instability (e.g. stigma related to disruptive behaviour, high housing turnover, rent arrears, damage to property). We clearly stated in our collaboration with service providers our hypothesis (based on the literature, as noted above) that housing instability and stigma are associated. Their input was collated to ascertain the points of greatest consensus. As a result, the two areas identified as the least stigmatised were specific streets within Forest Bay (henceforth, FB) and Woodland Grove (WG). The two areas in the neighbourhood identified as the most stigmatised were specific streets within Park Rise (PR) and Grass Hill (GH).

We used these street allocations as defined population areas from which to draw our sample (of at least 25 households per area) through letterbox drops, a BBQ in the street to hand out survey invites and answer questions, followed up with door-knocking each house in the area to personally invite residents to take part in the survey. Doorknocking proved the best way to recruit participants because it personalised the invitation, and allowed participants to ask questions about the survey and their role to their satisfaction. At the door, we were able to arrange a mutually suitable time and place for the survey to take place, with reminder notices and information sheets provided to residents and the ability to take phone numbers for follow-up. The interviews were held at one of a number of local places most conveniently located and comfortable for participants, e.g. neighbourhood community centres, the local library, the community housing provider office, or in a small number of cases, in the person's own home.

The survey instrument

We used the Organisational Network Analysis (ONA) survey tool (Optimice 2009) to design and operationalise our data collection. It is a web-based network survey which allows for the organisation of network data prior to analysis. We utilised the ego-centric capabilities of the software, including questions to evaluate the alter-to-alter relationships of the ego, allowing for both ego and complete network data analysis post-data collection. The data captured through this tool was easily downloaded into Excel and UCINET 6 (see below) for analysis. Specific to SNA ego-net data collection procedures are the use of 'generators', or questionnaire items that elicit alters' names. There are various types of procedures for this (e.g. see Krebs & Valdis 2013:ch3), however in this study we utilised two forms of ego-net generators. These include 'name' generators, where participants are asked to list the (full) names of individuals with whom they associate a particular type of relation, such as who they enjoy socialising with. We included eight such measures. The second is a 'resource' generator, or an item allowing us to capture relationship ties that give the participant access to different types of resources (Crossley et al. 2015). We include two of these measures, which overlap with our 'bridging' social capital measures (see Figure 1). In addition, the design of our survey included 'name interpreters' which are questions about the attributes of the alters named by the ego (age, sex, residential location [at area, not street, level]), characteristics of the ego's relationship with each named alter (type, length, closeness and main form of contact), as well as the ego's perception of the relationships *between* the alters they name (type and closeness). This method is called 'cognitive social structure' and seeks a deeper understanding of how informants perceive their network, as well as discover the extent of networks, and the amount of consensus on network relations (Krebs & Valdis 2013).

As a data collection procedure however, capturing alter-alter data is time consuming for participants and thus to reduce this burden, we adopted the strategy of limiting each name/resource generator to five discrete names per measure. While there are clearly disadvantages to limiting how many alters an ego can nominate, such as the inability to capture the extent or actual size of an ego's network, this method is widely used primarily due to the practical time constraint inherent in allowing 'free-recall' (or unlimited alter nominations) (e.g. see Krebs & Valdis 2013; Carolan 2014; McCulloh et al. 2013). However, as the data analysis demonstrates, we quickly noted that restricting the name nominations to five was not limiting in the vast majority of cases due to the very small participant network sizes.

In addition to the social network data capture tools used in the survey, we designed the survey to capture a range of both attribute and qualitative data. Attribute data included basic demographic data related to employment and training, perceived social networks, housing tenure, social engagement, service access, neighbourhood perceptions and life satisfaction. The open-ended questions were intended to capture richer thematic data related to the above attributes, particularly pertaining to social engagement, participant perceptions of living in the area (including problems), missing services in the area, and anything else the participant thought to be important.

One of the benefits of SNA is that while it draws on disciplined and systematic means to analyse relational data, it also provides an opportunity to mix qualitative and quantitative methods, both in data collection and analysis. It does so by locating the actor in a broader structure and allowing space for the interpretation of participants' subjective meanings to be analysed throughout the process (Crossley et al. 2015:108, 124). As Carolan (2014) notes, 'contemporary social network analysis muddles the traditional divide between qualitative and quantitative strategies and

includes a mix of strategies, including statistical, algebraic, discursive, and cultural'. Collecting this data was possible due to the inclusion of open-ended questions, but also because the surveys were administered face-to-face. Though the ONA survey tool is designed to capture social network analysis data through participant self-administration, given the time needed to complete it (from 45 minutes to 2 hours depending on participant network sizes) and the anticipated demographic characteristics of our participants (including the elderly and people with low educational outcomes), conducting the surveys in an interview-style enabled personal engagement with the participant including a context to build some trust, consistent handling of the survey questions, fewer missed or misunderstood questions, and a substantially enhanced ability to gather data on open-ended questions with more depth and clarity around the intended meaning of the participant responses. Alongside the sampling strategy which required ongoing local presence in the neighbourhood through doorknocking, and the partnership with a local housing provider engaged in developing community initiatives arising from this research, these factors helped to counter the critique that SNA neglects the possibility of understanding how residents *imagine* communities, and ignores the content of social relationships (Blokland 2003).

To analyse the attribute and some aspects of the network data, we used Excel. For analysing other components of the network data we used UCINET (Borgatti, Everett & Freeman 2002), a comprehensive software tool which allowed access to various analysis methods including ego-level analysis. UCINET also has a visualisation tool, NetDraw (Borgatti 2002), with advanced visualisation abilities. The particular measures used and purposes for their use will be outlined in the relevant analysis sections. For analysis of thematic data, we used NVivo 10 (2012), a Computer Aided Qualitative Data Analysis Software (CAQDAS) tool which enables coding and thematic category building inductively from the text.

Measuring social capital

Measuring social capital has been described as an 'uneasy' and 'daunting' endeavour (Zavaleta et al. 2014). Multiple measurement tools have been developed to capture the elements of social capital as they apply in variegated contexts (see Zavaleta et al. 2014 and Agampodi et al. 2015 for comprehensive syntheses on social capital measurement tools; and Harpham et al. 2002 for a discussion of key measurement issues). We drew on a range of recommended measurements (e.g. Grootaert et al. 2004; Hurtado et al. 2011; Harpham et al. 2002) to develop an abbreviated framework for measuring social capital in our survey.

In this study we use ten measures of social capital, drawing on both bonding and bridging forms of social capital. The bridging social capital measures focus on civic engagement (volunteering and interests), influence and leadership. The bonding social capital measures include informal social engagement (socialising) and measures of trust (decision-making and personal worries). We also utilise social capital measures with a slightly different focus than found in bonding or bridging definitions, including two measures indicative of practical help and borrowing a small sum of money (see Figure 1). While social capital is not constituted entirely in these ten measures (see for example Agampodi et al.'s 2015 synthesis of social capital measures and tools), they successfully capture the key indicators of social capital found in reputable and widely used contemporary measures. In addition, to maximise the degree to which we captured participant's full social networks, we supplemented the specific questions with a general request to recipients to name anyone else not already mentioned to whom they were especially close.

In preparing our questions, we held discussions with our community partner, the community housing organisation managing the social housing in the neighbourhood. The community development worker in particular provided advice on the relevance and applicability of our draft questions to the specific community. One of the most significant changes that resulted from this was the replacement of the original question 3 (is there anyone in the community you could ask if you needed to borrow something, like a cup of sugar or a tool?) with the question about borrowing \$20. Her advice was that an informal lending economy existed in the area, with people borrowing and repaying small amounts amongst themselves to tie them over from pay to pay. Our experience in asking this question was that it did resonate with the experience of the overwhelming majority of participants, and, as can be seen from Table 9 below, was one of the most effective name generators in the survey.

Figure 1. Survey questions by type (social capital measures/name generators & resources generators)



Interpretation:

- Dark blue** = bridging social capital questions
- Medium blue** = bonding social capital questions
- Light blue** = other social capital questions
- No outline** = name generators
- Yellow outline** = resource generators

During analysis, the classification, as either bonding or bridging, of two of the types of social capital emerged as problematic — hence their classification as ‘other’ in Figure 1. The responses to ‘help with tasks’ indicate that this is not clearly a matter of bonding social capital; a number of participants relied upon service providers such as gardeners or in-home support services for this purpose. But ‘help with tasks’ does not fit easily into a typology of bridging social capital either. Similarly, ‘ask for \$20’, while ostensibly a question about economic relationships, relates to a practice which is informal and situated in the local context. As a result of the ambiguity, these two measures are analysed separately throughout.

Participant profile

One hundred and two people took part in the survey interviews. The sample consisted of adult females and males, with a higher number of females (71.6%) than males (28.4%). Census data shows there is a slightly higher representation of females across the area (52.7%) than males (47.3%) (ABS 2013), but the higher number of females participating in the survey is also consistent with our recruiting technique of doorknocking during week days, when females are more likely than males to be home and available to participate. The age range of participants was 24 to 83 years, and both the mean and median age of respondents across the sample was 49

years, significantly higher than the general mean age of 30 years for the neighbourhood (ABS 2013). The composition of participant households included 58% of respondents in single or couple households with no dependents, and 42% either in single or couple households with dependents. Thirty-one per cent of participants lived in single person households, and 26% were single parents living with one or more dependents. The majority (80%) were renters, and 78% of these people (n=62) rented from the local community housing provider. Nineteen per cent of participants were owner-occupiers (either with a mortgage or fully owned). Almost half of the participants (n=47) had lived in their current dwelling for 10 years or more, and 60% (n=61) had lived in their current dwelling for 5 years or more. Even higher numbers of participants (80%) had lived in the neighbourhood for 5 years or more, with 69% living there for 10 years or more.

Relatively low numbers of participants were engaged in paid work (17.6%), and the majority (94%) received some or most of their income through Centrelink. Education levels were generally low, with 56% of participants obtaining up to or below year 10 as their highest education level, 21.5% obtaining a vocational education, and 5% having completed a tertiary education degree or higher. At the time of the survey, 6% of participants were engaged in some kind of study or training.

Table 1 summarises the main socio-demographic characteristics of the 102 participants. Tables containing all the applicable socio-demographic data are included in the first section of Appendix 2.

Table 1: Summary of participant characteristics

n=102		Tenure length	
Gender		At least 5 years	47%
Male	28%	At least 10 years	60%
Female	72%	Years in neighbourhood	
Age		At least 5 years	80%
Median age	49 years	At least 10 years	69%
Household characteristics		Employment status	
Single/couple with no dependents	58%	Employed	18%
Single with dependents	26%	Study or training	6%
Couples with dependents	16%	Main income source	
Housing tenure		Centrelink payment	94%
Renting: community housing	75%	Highest educational attainment	
Renting: private	6%	Year 10 or below	56%
Home owner	19%	Vocational	22%
		Tertiary or higher	5%

Findings

Neighbourhood stigma

External stigma

The vast majority of participants (94%) acknowledge, often multiple times, that their neighbourhood has a negatively tainted reputation, particularly in the view of people living outside the area. Across 102 participants, there are 296 comments referencing perceptions of the neighbourhood, and the people within it, as stigmatised. The following word cloud (Figure 2) highlights some stigma-related descriptions used by participants in response to the question ‘how do you think people from outside the area perceive this neighbourhood?’ The most prominent terms were variants of 'scum', followed by variants of ‘thieves and druggies’ and ‘bogans’.

Figure 2: ‘Stigma’ descriptors used by participants



Three key themes were identified in the way participants talked about neighbourhood stigma. First, participants talked about the source of stigma as arising from bias and judgement. Second, their response to stigma was resistance to the label, often by contrasting their neighbourhood with other areas. Third, participants talked about the symbolic and material consequences or outcomes of stigma for themselves and their neighbourhood.

Many participants felt that negative perceptions of the neighbourhood were caused because others from outside the area judged and stereotyped the neighbourhood and the people living in it. For example:³

They think — people who live here think they're being run down and talked about and people get their dander up about it. (P2⁴)

People who live outside see this as scumville. When I had internet, I read the *Mercury* [local paper], and comments. Anytime anything about [the neighbourhood] came up, people — [other affluent suburb], rich — would say, "scumville". Have you ever been out here? (P9)

I went to Pumpkin Patch and asked for a catalogue and they wouldn't send it because I lived in Woodland Grove. (P52)

People give us an image, and just keep to it. Once you've been put down, people think "I may as well be like this". (P58)

I think a lot of people stick to themselves, they don't want to connect with others — the reputation goes first. People judge a book by its cover without getting to know people first. (P68)

It doesn't make you feel good; they're branding you and discriminating against where you live. Sometimes people have a fear of this area. Because of the low employment in the area, we get put down. (P91)

Many respondents also resisted the label and often expressed anger or frustration at what they saw as its inappropriateness and unfairness. This confirms McDonald's (1999:112) observation that in disadvantaged contexts, a crisis in subjective creativity will often manifest as anger. In this context, the persistent negative labelling so at odds with the participant's subjective experience invokes such anger. The following responses were drawn from the question 'How do outsiders' perceptions of where you live make you feel?'

Makes me angry. It's not fair for an area to be stereotyped, or stigmatised. (P9)

I feel like smacking them — and want to say they shouldn't judge a place until they have lived here. (P15)

I hate it. I don't find anything wrong with it [the area]. It's how you treat people — you treat people all right they'll treat you alright. (P23)

I get angry about it at times — one bad apple spoils the bunch. So many people out here try really hard, but saying you live here means that people don't get back to you. No wonder kids can't get jobs because of the stigma of the place. (P24)

It makes me really angry that people say that when they haven't lived in the area themselves. (P32)

³ These quotes were noted in-situ by the researchers who typed notes as participants were responding. Consequently, while the researchers made every effort to quote the participants correctly and are confident that the meanings of the quotes are accurate, we cannot claim that the quotes are, in fact, verbatim.

⁴ 'P2' refers to 'participant number 2'.

Angry — when others say you better put an electric fence up. You get crime everywhere. We worked hard to be able to buy here, and comments like this put a downer on that — very upsetting. (P42)

It makes me angry that people judge people from here — I don't like it. (P51)

Makes my blood boil. (P65)

I have had fights over this. (P92)

Angry, upset. It's my home. If they haven't lived here, they shouldn't judge it. (P97)

Resistance was also evident in arguments that the conditions contributing to the neighbourhood reputation can be found equally (or to a greater extent) in other suburbs:

[This neighbourhood] is no different to [other working class suburb 1]. They have trail bikes and break-ins and house fires. (P11)

[It is viewed as] a rough, criminal housing department area, which it is not. The whole of [the neighbourhood] would live in [other affluent suburb] with no problems. (P31)

People put stigma on the place — we pay our bills, [other affluent suburb] don't. We don't pretend we're people that we're not. What you see is what you get. (P54)

I have a few mates who don't like coming out here — think they'll get their cars stolen, but more chance in [other working class suburb 1] and [other working class suburb 2]. (P55)

There is still prejudice that it is still bogansville. My brother lived in [other gentrifying suburb] and couldn't leave anything outside. (P67)

There's good and bad in every area. Lot of kids up here went through high school and all got top jobs. Look at the stuff that happens in [other working class suburb 1] — come on. That's unreal, that place. (P77)

I don't believe there's any more violence here than there is in [other affluent suburb]. I've lived in areas like that before — there's no difference, really. (P93)

It is impossible to get a job — they look at your suburb and say, "as if we're going to hire you". Major stigma. And I can understand, but has anyone thought to think that [other working class suburb 1] has gotten worse? Because a lot of people from here are moving to [other working class suburb 1]. [Other working class suburb 1] is bad — my partner has said he doesn't want me walking around on my own with the kids. Because random kids pick on other kids with their parents. (P101)

Third, participants highlighted both the psychological and material consequences of neighbourhood stigma. Warr (2005b:289) notes that: 'The effects of stigma are translated into practical experiences, across a range of psychological, social, and material conditions ... and this serves to deepen and extend the difficulties that impoverished people experience'. The psychological outcomes included a sense of inferiority, of feeling less than others, or 'not quite

whole', as if the whole suburb has been 'painted with the same brush' (P22). The personal impact of stigma is apparent in these accounts which describe how it creates social withdrawal, a sense of inferiority and generates harmful self-fulfilling prophecies:

Because they feel judged, so they keep to themselves. (P42)

[People make me feel] like a loser when I know I'm not. (P52)

People assume you'll do these 'bad' things if you live here, but many don't. This is a negative thing for the community. (P53)

The area has a bad name which is not deserved. People have no incentive to do better. A better perception of neighbourhood = a better perception of themselves. (P63)

Sort of makes you feel like, "oh, don't talk to me you're not good enough because you come from Grass Hill". (P94)

Material consequences of stigma referred to by participants included being under-resourced (e.g. in relation to parks and activities or services) and experiencing occupational setbacks (e.g. job or training insecurity). Un- or under-employment is often correlated with stigmatisation, as work itself is a primary means to becoming accepted as a full member of society (Ezzy 2000:199):

I've been to job interviews where they say "you're from Park Rise?" and then their attitude with the questions change. They think you come from there so you can't be trusted. You can tell from the tone of their voice that they've already made their decision and they're just asking the questions to be nice. I've been to so many and I can just pick it up now. And they've always got a different excuse why they haven't hired you but you can tell on their face why. (P2)

[When you] fill out forms and you put your suburb on it and you feel like you do get judged (P13)

If people here weren't continually put down and disadvantaged, there wouldn't be so many problems. If everything people needed was here (like everywhere else) they would take pride in the area, and life would be better for people. There's nothing here...skate parks, pools, playground areas. We're the forgotten suburb. (P24)

People look down their nose. I say I live in the Devingdale area, which works better. Hubby installs alarms, and he went to a meeting, and his bosses asked him not to sell in the Forest Bay/Park Rise and Woodland Grove area. Why? "Not the kind of area we want to sell there". (P53)

Story when I was in college doing a VET cert. in hospitality. The person running it told me that he couldn't trust me with a placement because I was from Woodland Grove, because he couldn't trust I would turn up. (P57)

They look down on you — you are nobody. I have found that when you go for a job and they find out you are from Woodland Grove they don't want to know you (P34)

It's mainly unemployment — [this neighbourhood] has a reputation as where the unemployed go. (P68)

People change their address to get jobs. There is a stigma about this area. (P91)

Intra-neighbourhood stigma

Intra-neighbourhood stigma was also a key theme in the open-ended response data. Intra-neighbourhood stigma was evident in the way participants talked about stigma generated *within* the residential neighbourhood. For example, almost half (or 46%) of participants describe problems *within* the neighbourhood that they regarded as the source of the area's spoiled reputation. This was identified in two different ways. First, participants referenced particular 'types' of people as the problem (or part thereof), for example, 'drug addicts', 'young hooligans', and 'bad parents'. Whatever the case, it was 'them' but not 'me' (the participant) who gave the neighbourhood its bad name. Some examples include:

You've got the good type ones and then the real bad ones. The area is what you make of it, if you keep to yourself. A lot of the problems in the community with drugs etc. come from people socialising, putting their money together and buying drugs, and that's where a lot of trouble starts from. (P19/PR⁵)

Some people own homes and work; others don't work and do it tough, which adds to the stigma. There are a lot of young mums who shouldn't be, get paid a lot to have a baby, and get stuck in a rut of having more babies because they don't want to/can't work. It's bad. "An idle mind is an unhealthy mind", and I agree with that. (P21/PR)

They class it as scum. They call Woodland Grove, "scum-grove", and Park Rise, "tip-rise". You get the arseholes no matter where you go, but most people here are not like that. [We] had property stolen a few times, but all from young (e.g. 15 year old) people. Nothing you can do. (P23/PR)

The way people are parenting their kids; kids run the show now. You can't do anything about it, or your house is gone (retribution). We used to leave keys in the doors, but now it is like living in the Bronx half the time. (P38/GH)

The rubbish just thrown on the street and people's lawns. The actual people who live in housing commission — they don't look after their property — someone who needs a house can't have that property. (P47/GH)

Horrible, because it is just the same as any other place; half of us work hard to get where we are — [we're] not just all dole bludgers and thieves like they think we are — so very downgrading and upsetting. (P54/WG)

Every place has issues — just takes a handful of people to screw up a place and that's pretty much what has happened. (P88/GH)

There's a lot of decent people just trying to make a living and they've had to be in this area because of the housing and everything else but they're just trying to make life like everyone else. And then you've got the scum, which just gives the bad reputation. (P101/GH)

⁵ P19/PR refers to 'Participant number 19, from Park Rise'.

Participants also referred to particular neighbourhood areas (e.g. streets or area within the neighbourhood) as having a worse reputation than the others. This is an *intra*-neighbourhood stigma in which participants identify one particular area as the cause of the wider neighbourhood stigma, or where one area is widely perceived as more stigmatised than others. This type of intra-neighbourhood stigma was indicated in 45 references by 33 participants. The area most commonly identified as the worst area, and the source of much of the neighbourhood's stigmatised status, was Woodland Grove, with 35 comments referring to this. Significantly, this perception was internalised by half of the Woodland Grove participants, who between them made 18 of the comments. 14 comments were made by participants living in Forest Bay or Park Rise (mostly Forest Bay) and only 3 comments from Grass Hill participants. Examples of intra-neighbourhood stigma *toward* Woodland Grove included:

[Q: Is there anywhere you avoid spending time in the area?] Top end of Woodland Grove, because of drugs and speed, and there the Housing Department dumped all the idiots. (P34/WG)

I always say [I'm from] Grass Hill, not Woodland Grove, as people are far more favourable about that. (P38/GH)

I've been warned not to go there. Never make friends with anyone from there or bring them to your home. It is probably putting a black mark on people, but I have been warned they are all tarred with the one brush. Just repeating what I've been told. (P66/FB)

Woodland Grove, I stay away from. When I worked for Devingdale Council we were told to be careful in Woodland Grove and to look out for each other. (P68/FB)

...it's this business with the car stealing and burning out. That's getting beyond a joke out here. Mostly happens in Woodland Grove, doesn't it? (P71/FB)

Woodland Grove. I call it the dark side. I had to go over there one night after dark for my sister-in-law. She wanted me to pick up something for her. No lights in the front of the house I had to pick up something from... scary. (P77/FB)

Bottom side of Woodland Grove -- unless it's life or death situation, no use going down there because of drug use. (P88/GH)

But Woodland Grove participants also described being stigmatised by others in the area. For example:

The thing is if I tell someone I live in Woodland Grove it's like I am a lower class citizen. (P40)

Woodland Grove has more of a name than Forest Bay/Park Rise ... And a lot of the time they say "Woodland Grove" on the news but it's actually towards [nearby suburb] — not in Woodland Grove — but because it's in this area, it happened in Woodland Grove. Or the person is from somewhere else but they have to mention Woodland Grove — the media portrays it as being a bad area too. (P46/WG)

...if something bad happens on the news they say Woodland Grove, and if something good happens, they say Forest Bay or Park Rise. There is also a local perception that Forest Bay/Park Rise are better than Woodland Grove. (P53/WG)

Burnt out cars. Crime. State of people's yards — just because you are renting you still need to take care of the property. [—] Rd [Woodland Grove] at the start is a mess, the yards need to be cleaned up. (P59/WG)

There is rivalry between Woodland Grove and Grass Hill, especially since they've changed their name. Topside [Grass Hill] is more "upper-class" - they think they're just a bit better than Woodland Grove. For Forest Bay/Park Rise, and Woodland Grove, there's always been rivalry, mainly because Woodland Grove, we put ourselves apart from everyone else and say "this is us". We identify with Woodland Grove, not Forest Bay/Park Rise. (P60/WG)

And if anyone says, "oh Woodland Grove, how can you live in Woodland Grove?" — I just say, "well, it's what you know, it's what you make of it". (P61/WG)

[The] stigma that we get: "Oh from Woodland Grove?" ... It seems funny that people who are really hard on their luck wouldn't go and live out at Woodland Grove. There's good and bad in every community, no matter what. (P65/WG)

The attribute data also contributes to our understanding of the dynamic of intra-neighbourhood stigma in the area. For example, Woodland Grove residents were the most likely to agree that 'the way outsiders see the area has a big effect on people living here', as well as the most likely to agree that there are people in the community who are isolated and don't take part in community events. Forest Bay and Park Rise participants were least likely to agree that some people are isolated, but Forest Bay and Grass Hill were the most likely to agree that 'In this neighbourhood, I have to be alert or people will take advantage of me' (see Table S1, Appendix 2). Forest Bay participants also had the highest levels of satisfaction on all indicators (with housing condition, neighbourhood safety, physical health, mental health, choice and control and life overall) (see Table S2, Appendix 2).

The average number of participants to view issues as problematic in the area was almost double for those from Woodland Grove (49%) what it was for those from Forest Bay (27%), with the latter much less likely to identify things as problems than Park Rise (42%) and Grass Hill (45%) (see Table S3, Appendix 2). More than half the participants for Woodland Grove, Grass Hill and Park Rise indicated either a minor or major problems included rubbish and general appearance, abandoned and burnt out vehicles, and vandalism and graffiti. Among Woodland Grove participants, half or more indicated problems with the lack of unity in the community, inadequate public transport, noisy neighbours, problems with children or youth, and drug use and dealing. For participants from Forest Bay, however, the proportion of participants identifying different issues as a problem was less than half in all cases (see Table S4, Appendix 2).

When post-coded for themes, responses to the open-ended question 'what are your three top dislikes about living in your area?' were consistent with the above findings (see Table S5, Appendix 2). Just over one quarter of Forest Bay participants had no dislikes at all to report and they identified less than half the number of dislikes (n=26) as were identified by participants from Grass Hill (n=55) or Woodland Grove (n=49). Key themes for Park Rise, Grass Hill and Woodland Grove were their dislike of negative and disruptive behaviours (e.g. stealing, vandalism,

disrespectful behaviours); and use of motor bikes and unregistered vehicles in the area (e.g. hooning). A lesser theme for all areas was problems with the appearance of the area (e.g. unkempt residences, broken glass and property damage, or burnt out vehicles).

Together, the attribute and open-ended data strongly suggests that across multiple indicators, Woodland Grove participants in particular felt stigmatised by other neighbourhood residents and report higher numbers of problems associated with living in the area. On the other hand, Forest Bay participants are most likely to highlight areas within the neighbourhood other than their own to be unsafe, and to perceive their own area to have less problems than other areas do.

Stigmatisation and housing stability

The findings with regard to externally applied and intra-neighbourhood stigma suggest both play into neighbourhood effects. This includes the impact on employment outcomes, with participants from all areas relaying their experiences of heightened difficulty finding work due to where they live:

My son when he lived here had no way of getting a job — as soon as you say you live here, no job. Moved out of here and got a job straight away. (P23/PR)

Some people it doesn't affect them but other people that do stuff with their lives, it can affect them (e.g. running a business or working). They find it difficult to find work. Affecting me looking for a work a little bit (postcode on the resume). (P50/WG)

My son said I won't get a job if I say I live in Forest Bay. I've already heard others say this as well. (P66/FB)

I avoid saying I live here — I say I live at Devingdale (getting a job, getting a house). I've missed out on apprenticeships and jobs because I've said I live here. (P88/GH)

Participants also talk about stigma detracting from the value of their housing:

Because of the stigma that is put on to them by others. The same home here and in Old Beach would be half the cost. (P31/FB)

This [outsiders' stigma] affects house prices. (P63/WG)

The stigma affects our house prices. (P70/FB)

They do not want to buy in Forest Bay and they certainly don't want to buy in Woodland Grove. You can get a house over there for \$110,000 and no one will buy it. I've had a lot of trouble selling this house. Even people at the mainland won't even touch it. It's taken me three years to sell it, and that's a long time. And I know for a fact that the people who bought it rang up the police station and asked what the area was like. (P71/FB)

Perceptions that the stigma associated with their area negatively effects employment and property values does not necessarily result in high levels of residential mobility (although c.f. DHHS 2010:3). Our attribute data shows a high level of housing stability amongst the sample (see Table S6, Appendix 2). Almost half of the sample (n=47) had lived in their current housing for ten years or more, and more than a further quarter (n=27) had lived in their current dwelling for

between three and 10 years. When asked how long they have lived in the area, 60% of the participants (n=61) had lived in the area for 10 years or more. In fact, despite the reputation of the neighbourhood, many participants indicated that they would not move from the area. For example:

A good place, I like it and intend on staying around for a long time. (P4/FB)

I just like Park Rise! Both my husband and I like living here — we won't move. (P10/PR)

Why wouldn't I want to move? I know lots of elderly people around and it's nice to run into them and have a yak to them. I've known them all my life. (P19/PR)

I love living here. I'm happy here, and when I have to move, I'm going to be very sad. (P21/PR)

Happy here — I don't like moving, so why would I? What goes around comes around; if you're friendly to people you get it back. (P46/WG)

Now I love it here. If I go away, I love to come back. (P51/WG)

I do love the area. Just because I've been here for so long — I don't want to move out of here. If I could buy my house I would. (P65/WG)

It's not a bad place to live. I wouldn't move. (P82/FB)

I hope to live here to the end of my days. I don't wish to move anywhere else. (P84/FB)

With respect to their housing histories, 17 participants indicated they had, in the last five years, either experienced homelessness, received one or more eviction warnings, or had been evicted from their home. All but two of these participants were from Park Rise and Grass Hill, suggesting that the service providers who afforded us their opinions about the geographical overlap between stigma and housing stability were largely correct.

But contrary to our assumption that the areas characterised by the greatest housing instability would also experience or perceive greater intra-neighbourhood stigmatisation, our data tells a different story. The data shows that Woodland Grove was the most internally stigmatised area but the housing variables in our dataset show that these participants had more stable housing histories than respondents from other areas and had experienced relatively low levels of eviction and homelessness. They equal the number of Forest Bay participants with respect to home ownership, have the highest number of participants who have lived 10 or more years in their homes and have lived the longest in the neighbourhood (10 years plus). Far from being economically excluded, the Woodland Grove participants had an average of three times more participants (at 31%) engaged in work than participants from other areas (11.5% for FB, 12% for PR and 8% for GH), and the highest number of participants with no Centrelink contributions to their income (see Tables D4 and D5, Appendix 2). By all our indicators of housing stability, the Woodland Grove participants were the most stable, and least disadvantaged of the four groups in the study. This also conformed to the views of our service provider informants who had identified these sections of Woodland Grove as a less problematic area of the neighbourhood. There was, therefore some dissonance between the objective findings and service provider views, and the views of those who lived in the area who overwhelmingly viewed Woodland Grove collectively as

'the' place to avoid, a perception internalised strongly by Woodland Grove participants themselves.

The attribute and qualitative data therefore suggests that in this study, stigma — and in particularly intra-neighbourhood stigma — is not necessarily correlated with housing instability. It also suggests that areas identified by service providers as having higher numbers of people with problematic housing situations are not necessarily the most stigmatised residents or areas in the neighbourhood. The following section, detailing the social network analysis data findings, will provide some insight into possible correlations between stigma and neighbourhood relational dynamics.

Neighbourhood social connections

On average, the survey participants perceived themselves to be well-connected, both within and outside the suburb. Participants were asked to estimate, broadly, the number of people they ‘knew’ in and outside the neighbourhood, with ‘knew’ defined in terms of feeling comfortable to start a conversation with them, should they run into them in the street. Because responses were categorical (based on ranges), not valued, the averages (in Table 2 below) have been calculated on the lowest figure in each of the categories. This means the figures in Table 2 are most likely under-estimates, and probably considerable under-estimates, of participants’ perceived networks (see also Tables R1 and R2, Appendix 2).

Table 2: Perceived extent of social networks, by area

Area	Number of perceived ties	
	Within neighbourhood	Outside neighbourhood
FB	21.4	23.9
PR	22.6	20.2
WG	23.5	25.6
GH	19.2	24.2

These figures show that respondents from Grass Hill had the lowest number of perceived ties within their area, and the second highest outside, while respondents from Woodland Grove had the highest perceived ties both within and outside their area. However, as the next section shows, while most participants described being extremely well connected (more than one participant declared in response to this question that ‘I couldn’t count them!’ or laughed at the thought of trying to), their specific personal networks were actually not so extensive.

Network characteristics

In this study, we made extensive use of the capacity within social network analysis to include ‘name generator’ questions. These are questions where the participant is asked to name particular individuals with whom they have a relationship, and to then describe aspects of that relationship. As discussed above, our questions concerned measures of social capital, interests and volunteering involvement. Obtaining these names allowed us to map individual ego-networks for each participant. Figures 3 and 4 show two examples of these ego-networks, chosen because they represent extreme (though not the most extreme) cases.

Figure 3 (see below) shows P65’s involvement in a relatively large and densely interconnected network of 13 people, as well as four further relationships with others less connected to her core network. In all, she has named 17 ‘alters’ in her network, and there are 145 directed⁶ ties between them. The multitude of connections amongst alters means that her network is relatively dense, compared with those of other participants. In contrast, P12’s network, shown below, is much more sparse and disconnected internally. He has named only six alters, and in only one case do these alters know each other. Consequently, his network has very low density.

⁶ Taking into account tie direction means that reciprocal ties are counted twice (i.e. a relationship between A and B will be counted as A > B and B > A).

Figure 3: Ego-network, participant no. 65

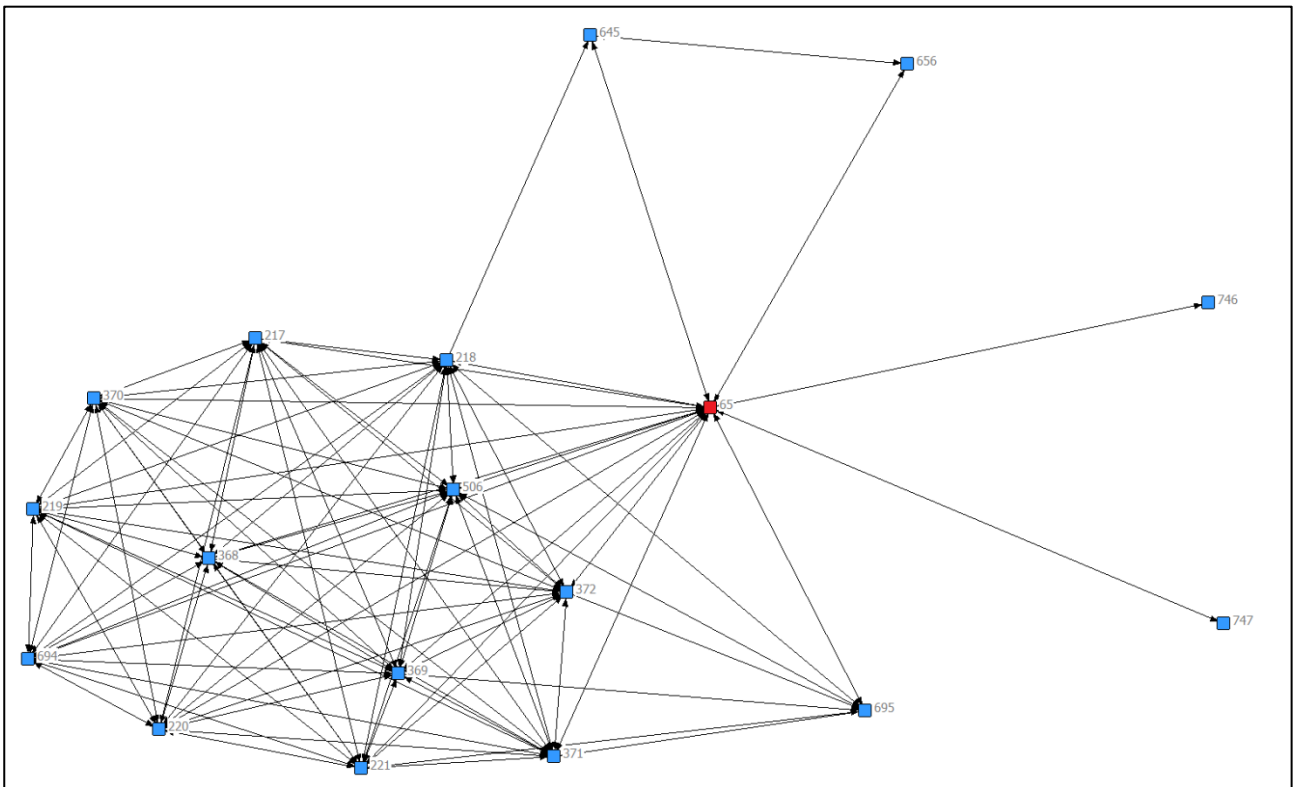
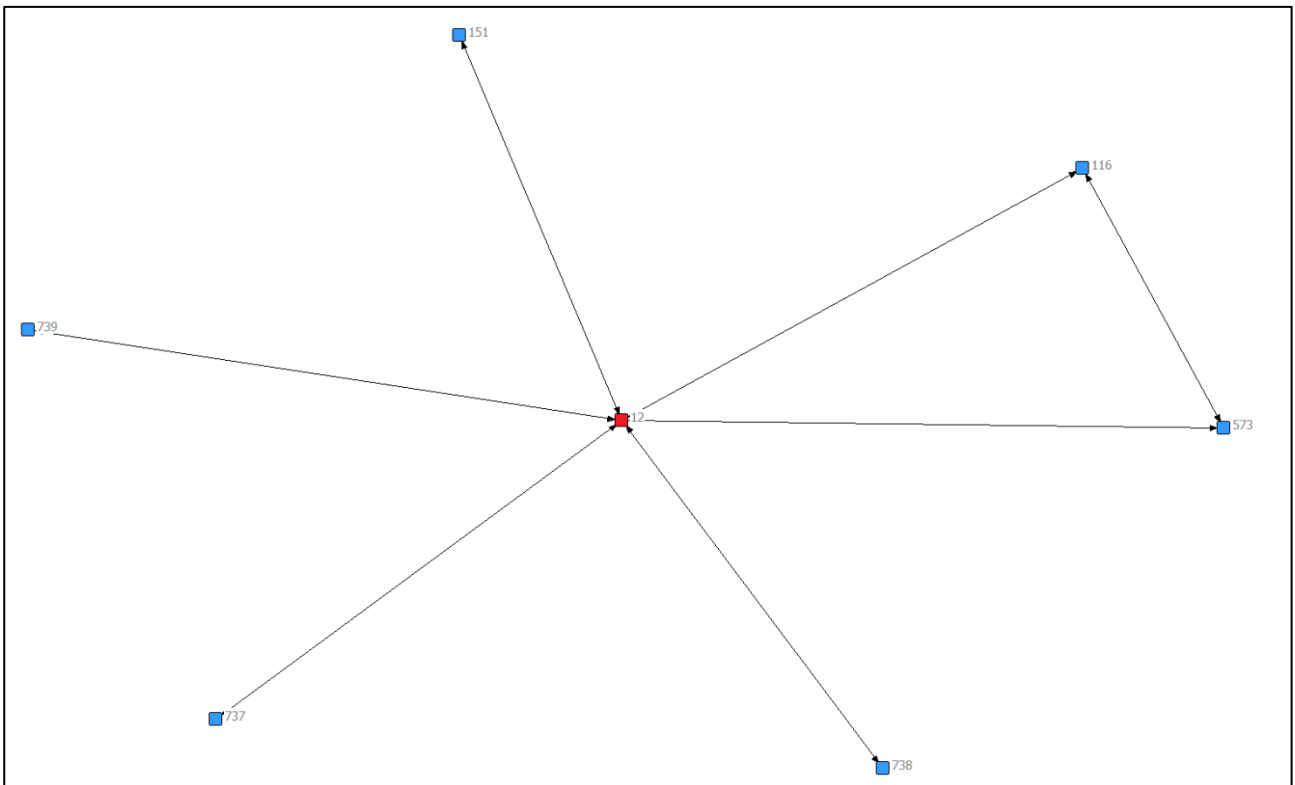

Figure 4: Ego-network, participant no. 12



Note: Figures 3 and 4 generated through NetDraw software.

The ego-networks of all 102 participants were analysed and compared on the basis of the area in which the ego lived (that is, Forest Bay, Park Rise, Woodland Grove or Grass Hill). Tables 3, 4 and 5 below show various measures, some calculated manually (in Excel) and others derived using UCINET software. For these tables, the ego network is defined in terms of whether or not a tie exists between a given pair of actors (rather than, for example, being defined as ties of a given strength between actors). In each case, the measures have been calculated individually for each participant, with these individual measures used to calculate an average for all participants in a given area, and an average overall. The tables present different but inter-related measures of network characteristics. At the bottom of each table, the relevant measures for P65 and P12 are included to give the reader a point of comparison.

In Table 3, various components of the individual ego-networks have been calculated in order to generate a measure of network density, meaning the extent to which the various members of the network are inter-connected. Table 4 also contains a calculation of density, one generated using different network measures. The other measures in Table 4 and the measures in Table 5 are measures of how the ego is positioned within their own social relationships. In these cases, the way in which the measures are determined rest on a normative conceptualisation of social networks that is in some ways quite different to the way in which our participants live their relationships day-to-day. The measures of ‘weak components’, brokerage, ‘between-ness’, ‘effective size’ and ‘constraint’ all relate to the extent to which an ego is able to exert influence within their immediate circle. ‘Broker’, for example, captures the situation where the ego is the only link between two actors. This means the ego can control the information flow from one of those actors to the other. ‘Constraint’ is derived from work done by Burt (1992) in a book that set out to theorise the social structure of competition. A ‘constrained’ ego is one whose alters know each other independently of ego, and can therefore act together to their benefit and ego’s detriment. The underlying conceptualisations do not make the measures irrelevant to our research, but it does inform how these measures are read in the tables below. A more detailed account of how each of the individual measures is defined and generated is provided in Appendix 1.

Table 3: Average counts of ties in ego-networks by area
[calculated in Excel]

Location	No. of alters	No. of alter > alter ties	No. of unique alter > alter ties	Total ties	Density (measure 1)
FB	7.6	30.7	15.3	22.9	2.7
PR	6.8	23.0	11.5	18.3	2.6
WG	6.9	30.1	15.1	21.9	2.8
GH	6.1	18.4	9.2	15.3	2.4
Overall	6.8	25.7	12.8	19.7	2.6
P65	17	145	72.5	89.5	5.3
P12	6	2	1	7	1.2

The first point to notice is the dramatic differences in the number of alters (ties) shown in Table 3 and the perceived ties in Table 2. The averages for perceived networks exceed the averages for the actual networks in all cases by a factor of three or more.

Comparatively, participants from Forest Bay have slightly larger actual networks and participants from Grass Hill have slightly smaller networks, but overall the actual number of alters per ego is similar across the four areas. However, there are clearer differences in relation to the number of alter-to-alter (as distinct from ego-to-alter) ties. Alters in the ego-networks in Forest Bay and Woodland Grove are more interconnected to each other, independently of ego, than are alters in the ego-networks in Park Rise and Grass Hill. These differences are reflected in the averages for each area of total ties and of density, which in this case is calculated by dividing total ties by number of alters. In very broad and relative terms, compared to the average, Forest Bay participants have larger, somewhat denser networks, Woodland Grove participants have denser networks and Grass Hill participants have smaller, less dense networks. The size and density of Park Rise participants' networks and the size of Woodland Grove participants' networks are average or close to it.

The average size and density measures in Table 4 are calculated somewhat differently to the measures of alter numbers and density in Table 3 (see Appendix 1). However, a similar pattern is seen in relation to network size — the largest networks are in Forest Bay and the smallest in Grass Hill. The density measure, however, shows a somewhat different picture. This measure of density is designed in a way that controls in part for relative differences between participants in network size by focusing on the relationships, not the nodes — it is a measure of the actual ties that exist in the network as a proportion of the maximum possible ties that could exist in that network. According to this measure, although participants from Forest Bay have networks which, compared to the average, are larger, their networks are the least dense overall. Woodland Grove participants, by contrast, have the second largest network size *and* networks of notably greater density — even greater density than participant no. 65 (see Figure 3 above), whose network is actually only of average density according to this measure due to the presence of four alters who are relatively disconnected from each other and the rest of the network. However, Grass Hill has the lowest average measures of both size and density, suggesting, as does Table 1 above, that participants from this area have smaller, less dense networks overall.

Table 4: Average ego net measures by area

[calculated through UCINET routine: Network > Ego networks > Egonet basic measures]

AREA	n*	Size	Density (measure 2a)	Weak components (normalised)**	Broker (normalised)	Between-ness (normalised)
FB	26	8.62	48.63	44.32	0.51	44.32
PR	25	7.08	55.40	43.83	0.45	41.28
WG	26	8.12	59.98	36.03	0.40	30.91
GH	24	6.75	50.96	46.56	0.49	42.19
ALL	101	7.66	53.86	43.12	0.46	39.54
P65		17.00	53.31	17.65	0.47	39.93
P12		6.00	6.67	83.33	0.93	93.33

*One participant from GH was excluded because he had a network size of 0.
 **This measure is only meaningful where the number of weak components exceeds 1. Non-meaningful results were excluded, therefore in this column, n= 15, 17, 11, 14, 57 respectively.

Moving to the fifth column in Table 4, a ‘weak component’ is a case where the ego is the only connection between otherwise disjointed sets of actors (e.g. A, B and C all know each other, and D, E and F all know each other, but the only connection between the two groups is that A and D both know the ego). Using a percentage measure normalises the number of weak components according to the size of the networks (i.e. a very large network can be expected to have some weak components, so the question becomes, is the number of weak components unexpected, given the size of the network?). The larger the network for a given number of weak components, the smaller the normalised measure will be. According to this measure, participant no. 65’s network has a much lower percentage of weak components than might be expected, given the size of her network, while participant no. 12’s network has a very high proportion of weak components (as we can see from Figure 4). With regard to the averages for the four areas, it is evident that ego-networks in Woodland Grove have a lower percentage of weak components than might be expected, while Grass Hill ego-networks have a higher percentage. This aligns with the picture emerging from the density data – that Woodland Grove networks are more deeply interconnected, while Grass Hill networks are sparser.

Brokerage and between-ness (the sixth and seventh columns of Table 4) are both measures of the degree to which the ego is a key actor within their own network. An ego who can control the interaction between their alters by being the only link between them has greater influence than an ego whose alters all know each other independently of ego. The figures in Table 4 show that participants from Forest Bay have the greatest capacity to exert influence, while participants from Woodland Grove, whose networks are denser and stronger, have the least.

Effective size (in Table 5, below) similarly assesses the extent of ego’s influence; it begins with the number of alters (size), but modifies this by taking into account the degree to which alters are connected to other alters. That is, the starting premise is that not all of ego’s ties involve equal levels of influence within the network on the part of ego, so a large network can be, relatively speaking, quite small in terms of ego’s capacity to exercise influence on others. Behind the measure is the suggestion that duplicate ties are essentially redundant in terms of their utility to the ego (see Crossley et al. 2015:36).

According to measures of effective size, Forest Bay participants again have the largest networks. However, it is Park Rise participants who have the smallest. Finally, constraint, as discussed above, essentially measures the extent to which ego’s own actions are restricted by the connections between other people in the network. According to this measure, Woodland Grove participants are the most constrained while Forest Bay residents are the least.

Table 5: Average ego net structural holes measures by area⁷

[calculated through UCINET routine: Network > Ego networks > Structural holes]

AREA	Effective size	Constraint	Density (measure 2b)
FB	5.45	0.41	0.49
PR	3.87	0.43	0.55

⁷ Density, in Table 5, has been calculated on the same basis as it was for Table 4, but in this case UCINET expresses it as a ratio, not a percentage. It is included in Table 5 because, due to the way it is calculated, constraint is best read with reference to relative density. When dealing with averages it is not as critical, but when dealing with individuals, constraint measures become less helpful the more extreme the case.

WG	4.71	0.50	0.60
GH	4.11	0.46	0.51
ALL	4.54	0.45	0.54
Part. #65	8.47	0.19	0.53
Part. #12	5.67	0.24	0.07

These tables provide various ways of understanding the differences between areas in relation to the size and density of participants' ego-networks and their positioning within those networks. Setting aside the inconsistency in relation to the density of Forest Bay's networks (c.f. Tables 3 and 4), the overall picture, in comparative terms, that emerges of the four areas is as follows in Table 6.

Table 6: Summary of networks characteristics, by area

Participants from...			
FB	PR	WG	GH
have larger networks in actual and effective terms, & are able to exercise influence and act with least constraint	have smaller, less dense networks with the smallest effective size	have the densest and strongest networks, the least capacity to exert influence & are subject to the greatest constraint	have the smallest, least dense and weakest networks

At one level, these characteristics are unsurprising given the basis for selecting the study locations in the first place was their relative experiences of indicators of disadvantage and exclusion, such as unstable housing situations. The smaller, less dense networks among our participants are found in the two areas identified by local service providers as the most disadvantaged and stigmatised. However, the analysis below of the geography, quality and nature of the social relationships in the neighbourhood adds layers to the picture which problematise this explanation.

Relationship geography

The relationships identified through the name generator questions (i.e. the ego-to-alter ties) were analysed as to the location of both ego and alter – that is, they were treated as directional, with a beginning (or origin point) and end (termination point). Egos could only live in one of the four study sites, so therefore ego-to-alter ties could only originate from one of those four areas. But in identifying where alters lived, there were six options – in any one of the four study sites, outside the neighbourhood, or 'unknown' – which meant that the a given tie could terminate in any one of those six. The last option, 'unknown', was applicable when egos identified service providers or public figures as alters. It is important to note that the attribute data we collected on alters was not at street level, but refers only to which of the four segments of the whole suburb they lived in; this means that an alter location of 'Forest Bay' for example, cannot necessarily be conflated with the particular streets in Forest Bay from which we recruited our egos.

A summary of the results of this origin/termination point analysis is shown in Table 7 (a full breakdown is provided in Tables R3 and R4, Appendix 2). The area where the greatest number of

ties originated (i.e. where participants named the greatest number of alters) was Forest Bay (n=187), followed by Woodland Grove (n=171), while Park Rise (n=152) and Grass Hill (n=139) named the fewest. This is consistent with the measures shown in Tables 3 and 4 above, which show Forest Bay and Woodland Grove participants have the largest networks, while participants from Park Rise and Grass Hill had the smallest.

Turning to the ‘termination point’ of the ego-alter relationships — that is, the locations where the alters lived, the table indicates that nearly half (47.5%) of all the relationships identified by egos were with alters who lived outside the neighbourhood. For alters living in the neighbourhood, a higher number (n=85) lived in Woodland Grove (n=NS) and Forest Bay (n=82) compared to the smaller number in Park Rise (n=64) and Grass Hill (n=50). When alters living in outside or unknown locations are excluded, the respective percentages of ties ‘terminating’ in each of the four areas (n=281) is 29.2% (Forest Bay), 22.8% (Park Rise), 30.2% (Woodland Grove) and 17.8% (Grass Hill).

Table 7: Ego > alter relationships, origin and termination points, by area

Area	Ties originating in area		Ties terminating in area	
	No.	%	No.	%
FB	187	28.8	82	12.6
PR	152	23.4	64	9.9
WG	171	26.3	85	13.1
GH	139	21.4	50	7.7
Outside	—	—	308	47.5
Unknown	—	—	60	9.2
Total	649	100.0	649	100.0

The geography of these ego to alter relationships is represented in Figure 5 below. In this figure, arrows represent ties from one area to another. Six areas are shown, the four study areas, outside and ‘unknown’. The size of the arrows is proportional to the number of relationships in question. For example, the very fat arrow between Forest Bay and outside represents a large number of relationships (98), while the very thin arrow from Forest Bay at the top left to Grass Hill at the bottom right is scaled accordingly to represent a comparatively small number of relationships (5). The figures for each combination of locations are found in Appendix 2 below (see Tables R4 and R5).

Figure 5: Diagram of ego > alter relationships by area, arrows weighted to show relationship numbers

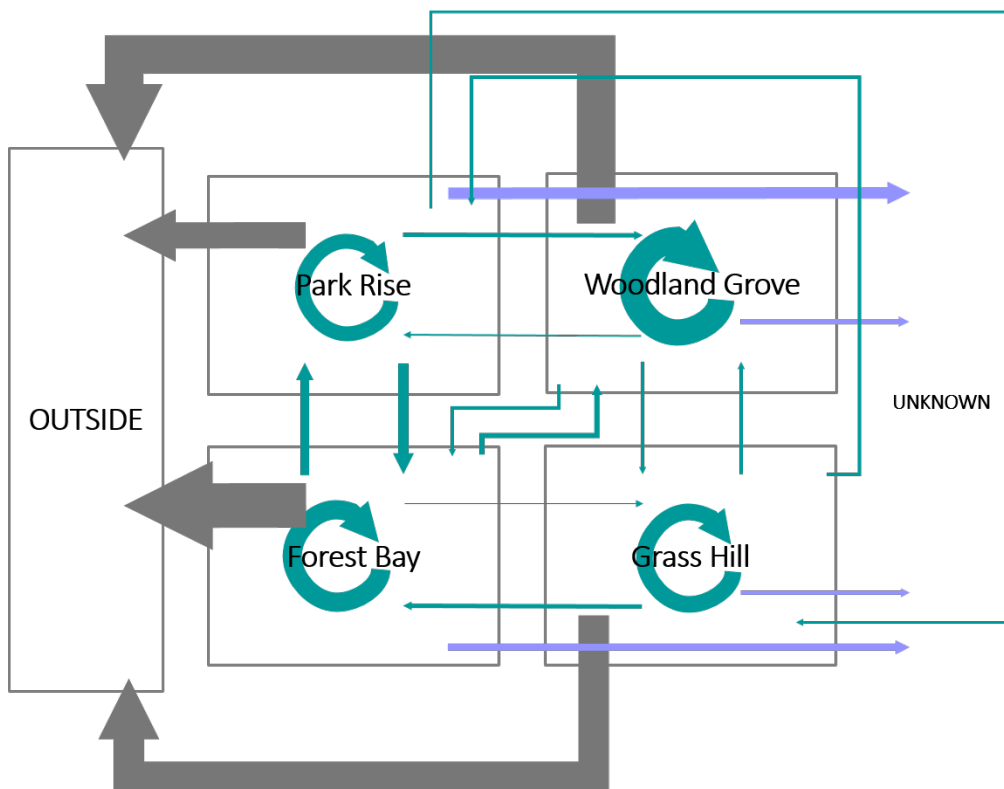

Interpretation:

Grey arrows indicate ties terminating outside the neighbourhood. **Teal arrows** indicate ties terminating inside the neighbourhood. **Purple arrows** indicate ties terminating in unknown locations. The **direction of the arrow** indicates the direction of the ties (origin > termination). **Circular arrows** indicate ties that originate and terminate in the same area. The **arrow size** is proportional to the number of relationships represented.

In providing an illustration of the pattern of relationships as they exist across geographical boundaries, Figure 5 makes clear in all cases the importance of ties terminating in external locations. It shows, with respect to relationships that originated and terminated in the same area, that Woodland Grove participants reported more of these than participants in other areas, and that different areas have different levels of reliance on alters whose location is ‘unknown’, with Park Rise reporting relatively more of these relationships than other areas. From Figure 5, we can also see that the two most connected of the four study areas are Forest Bay and Park Rise; there is very little connection between these areas and Woodland Grove and even less to Grass Hill. In essence, Woodland Grove is isolated from the other areas, but has a robust level of internal relationships. Grass Hill is isolated too, but its number of internal relationships is much smaller in relative terms.

Figure 5 shows only ego > alter relationships. Adding alter > alter relationships into this analysis, as has been done to produce Figure 6, has two effects. Firstly, it increases the complexity of the diagram because alter-to-alter relationships can be based on ties that originate, as well as terminate, in the Outside and Unknown location categories. Secondly, it dramatically increases the number of ties represented in the diagram, and the scale has been adjusted to compensate.⁸

⁸ In this diagram, alter > alter ties that have been added are directed ties (i.e. A > B and B > A are represented separately), while ego > alter ties are binary (i.e. a two way relationship between A and B is only counted once, as if it was only A > B). This is a peculiarity caused by the way the data was collected by ONA Surveys. In some cases in our analysis we tried to take account of it by inferring a two way relationship between egos and alters on the basis of the wording of the name generator questions we asked and manually adjusting the data. As this is not the case here, the

Figure 6: Diagram of all relationships by location, arrows weighted to show relationship numbers

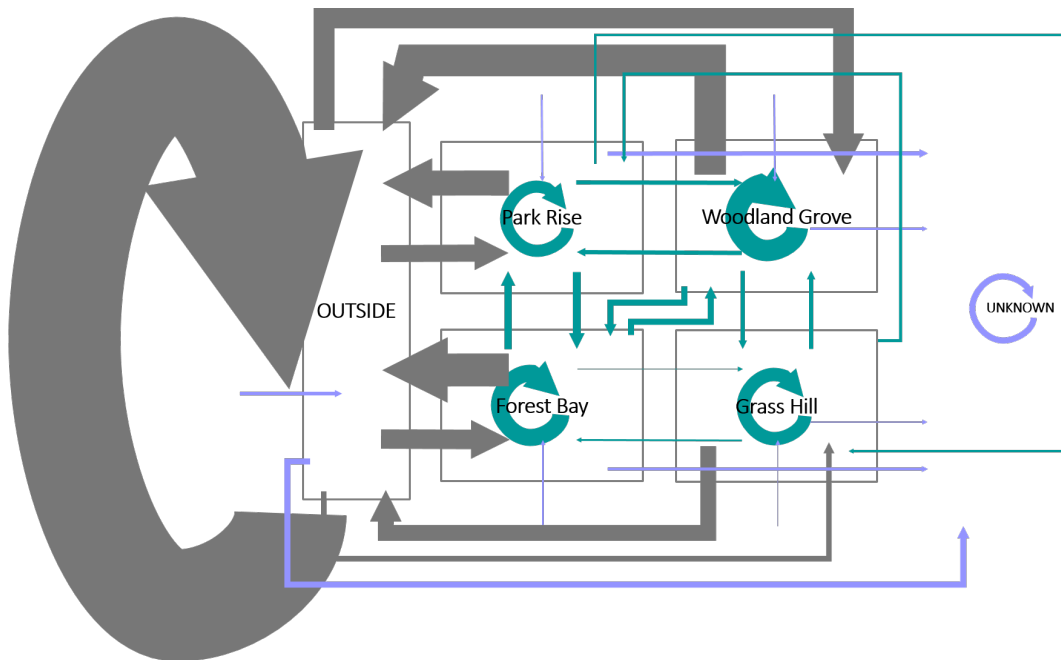

Interpretation:
Grey arrows indicate ties originating or terminating outside the neighbourhood. **Teal arrows** indicate ties originating and terminating inside the neighbourhood. **Purple arrows** indicate ties originating or terminating in unknown locations. The **direction of the arrow** indicates the direction of the ties (origin > termination). **Circular arrows** indicate ties that originate and terminate in the same area. The **arrow size** is proportional to the number of relationships represented.

Figure 6 is dominated by the very large proportion of ties that consist of relationships between alters based outside the area (886; for the full table of figures, see Table R7, Appendix 2) – something which is not unexpected given the number of alters who lived in external locations. However, the addition of alter-alter relationships also adds to the connections between Woodland Grove and the other areas, particularly Forest Bay. Woodland Grove also appears to have a proportionally greater number of relationships with outsiders. It is also clear, however, that Grass Hill remains isolated, even with the addition of alter to alter relationships. This applies even to relationships originating outside the neighbourhood – in the other four study areas, the number of these is substantial, proportionally on a par with the number of ties beginning and terminating within each area. In Grass Hill, however, the number of ties coming ‘in’ from outside areas is minimal.

Social capital

We used 10 name generator questions in this survey, and collected alter-to-alter information on eight of these. The basis on which participants were asked to provide names was that the person was not a member of their own household, was 16 or more years old, and was someone they ‘knew’, with this last being defined, consistent with the wording to the questions about perceived social networks, in terms of ‘feeling comfortable starting a conversation with them if you ran into

diagram should be treated as indicative only. Another limitation of the data that was used to create this diagram is that we do not have alter-to-alter data for volunteering and interest relationships, only for social capital relationships. This was a compromise reached during the survey development process to reduce participant burden.

them in the street'. The interest and volunteering name generators were follow-up questions to information collected earlier in the survey about volunteering work undertaken and interests ('what do you like to do in your spare time?'). Participants were asked for the names of anyone they volunteered with or shared interest-based activities with, such as a sport or craft group.

Table 9: Summary of most common volunteering activities and interests (open-ended, post-coded)

		n=102
Volunteering		
Extent of involvement		82
Types of activities	General assistance	50
	Driving for/with others	35
	Caring for others	32
Frequency of volunteering	At least once a week	60
	At least a couple of times a week	30
Interests		
Types of activities	Spending time with family & friends	35
	Gardening	28
	Reading	22
	'Pottering' at home	18

Our definition of volunteering was broad, including informal volunteering⁹. Based on this definition, 80% of participants (n=82) indicated they were involved in some kind of volunteering. The participant's open-ended comments referring to the kinds of volunteering they undertook were post-coded for themes (see Table R5, Appendix 2). This coding allowed for participants who indicated more than one type of volunteering. Of all indications of volunteering, only 9% of the total were coded as 'volunteering for an organisation', with 91% of indications for informal types of volunteering. Volunteering themes included providing care for other people (e.g. an elderly parent, or childcare for grandchildren), general assistance (e.g. cleaning, helping cook, gardening), peer support (companionship and advice), driving (for or with others to help with transport), financial help (either monetary or advice), and helping with housing and accommodation for others. The most frequent type of informal volunteering was 'general assistance', indicated by almost half of respondents (n=50, or 32% of all indications of volunteering types), followed by 35 indications (or 19% of all indications) of driving for/with others. Caring for others was indicated 32 times. There was a high frequency of volunteering, with 59% of participants volunteering at least once a week, and 29% volunteering at least a couple of times a week. A further 22% of respondents engage in volunteer activity, but less than once a week. However, although engagement in volunteering was considerable, because the bulk of it was informal volunteering — essentially helping others around them — the number of people who responded to the name generator question (by identifying their volunteer 'colleagues') was relatively low.

Participants were also asked about their interests, using the wording 'what do you like to do in your spare time?', and 247 pieces of data were identified from the open-ended responses. These

⁹ Consistent with Volunteering Tasmania's recent (2015) broad definition of volunteering, which is: 'Time willingly given for the common good and without financial gain.'

were coded and grouped, and this analysis identified considerable congruence between participants' stated interests and the character of their social networks (which is detailed below). The most common pursuits were solitary — two participants actually listed being on their own as an interest. Twenty eight participants nominated gardening, 22 nominated reading, 18 nominated various activities that could be grouped under 'pottering at home' and 17 nominated watching TV or DVDs. Craft activities (n=14), computer gaming (n=13) or other computer-based activities such as Facebook (n=7), fishing and/or camping (n=14) and walking, either alone (n=11) or with a dog (n=6) were also listed as preferred and more solitary leisure activities. This did not mean participants were a-social, however; collectively, there were 35 interest activities identified that could be variously grouped under spending time with children or grandchildren (16 participants), visiting friends (n=11) and spending time with family (n=9). Visiting friends was in most cases a domestic activity, meaning going to a friend's private home. Only four people indicated that visiting friends involved going to a third place, such as a café. Few participants identified organised interest groups — two attended a social club for the over 55s, and one of these also attended a knitting group. Five were involved variously in darts, bingo or card-playing. Two people played organised team sport.

The nature of people's interest activities determined the people they shared them with and the places where they did them. Only 28% purposefully included others in their interest activities. A further 35% did share their interests with others, but by default (i.e. the interest was 'visiting friends'). Thirty-six per cent of participants did not spend their leisure time with anyone else, and indeed, seemed to regard being alone as a prerequisite for considering the time 'free' — as one participant (P33) said, 'it's my time and I don't get much of it'. Similarly, when asked where they undertook most of their interest activities, most participants (60%) said their own home. A further 19% identified other private homes, and a further 12% said they went out to a park, café, community space or other generic location. Only 19 participants named a specific location or locations. As with the volunteering data, the essentially private, solitary and informal nature of people's leisure pursuits means that comparatively few explicitly named others as interest relationships when it came to the name generator questions (although those who did often identified multiple names).

Thus it was the other social capital questions (see Figure 1 in methodology) which generated the bulk of the data, and these were also the only ones for which we also captured data about the relationships between alters. Table 10 shows the number of relationships identified through each name generator question for each of the study areas. Overall, participants from Forest Bay and Woodland Grove reported larger numbers of ties, consistent with the data showing they have the largest networks. But with respect to individual name generator questions, the pattern is uneven. Forest Bay participants identified the most names in response to influencing change, socialising and help with tasks, as well as 'other' people to whom they were especially close, and those from Woodland Grove identified the most people in relation to important decisions and asking for \$20, but it was participants in Grass Hill who nominating the most people for good leadership, volunteering and shared interests. In no cases did Park Rise participants report the highest number of relationships and in the case of influencing change, good leadership, advice about important decisions, others to whom they were especially close, volunteering and shared interests, they named the fewest people.

Table 10: Number of ties identified by name generator questions, by area

Name generator	FB	PR	WG	GH	All areas
----------------	----	----	----	----	-----------

Bridging	Influencing change	17	7	12	11	47
	Good leaders	15	11	19	27	72
Bonding	Enjoy socialising	72	57	71	69	269
	Personal worries	44	42	49	40	175
	Important decisions	41	22	44	43	150
	Especially close	32	11	18	13	74
Other	Help with tasks	32	31	26	31	120
	Ask for \$20	50	48	60	44	202
	Volunteering	8	6	10	14	38
	Shared interests	40	38	46	58	182
ALL RELATIONSHIPS*		198	152	179	150	679
*The numbers in each column will not tally to the 'All relationships' figure because one relationship could be named in relation to more than one type of tie.						

It became evident during data collection that there was considerable overlap in people's relationships. Table 11 shows the proportion of ties unique to a single name generator, excluding the question about others who were especially close as the wording of this question explicitly excluded people already named in the survey. The table indicates that in almost all cases, more than half of the ties identified in relation to a given type of social capital are applicable to one or more other types. The proportion of unique ties ranged from as few as 10% (Grass Hill, personal worries) to as much as 57.0% (Park Rise, influencing change).

Table 11: Proportion of ties identified as unique to that type of social capital, by area

Type of social capital		FB	PR	WG	GH
Bonding	Influencing change	47.1	57.1	50.0	36.4
	Good leaders	43.8	45.5	47.4	41.2
Bridging	Socialising	36.1	43.1	33.3	19.7
	Personal worries	31.8	41.9	12.2	10.0
	Important decisions	19.5	21.7	11.4	18.6
Other	Help with tasks	43.8	35.5	53.8	12.5
	Ask for \$20	24.0	34.7	20.0	22.2

Some of the patterns might be expected given the nature of the question — 'good leaders', for example, could be expected to generate some unique names because it potentially asks participants to think outside their immediate personal circle. By contrast, 'personal worries' might be expected to produce very few unique ties because an alter who can be approached to talk about a personal problem could conceivably be the same person asked for advice about an important decision. However, the pattern is not entirely consistent across the four areas, and the implications of some of these variations are explored at different points in the analysis below.

As with the differences in the geographical distribution of relationships between egos and alters across the four study areas, there were also differences in the distribution of relationships involving the different types of social capital. Summary measures are shown below in Table 12 (more detailed figures are available in Table R8, Appendix 2). This table indicates that, as was the pattern more broadly, social capital ties of all kinds are more likely to be with externally-located

alters than anywhere else, and that ties within each area (that is, ties which originated and terminated in the same place) are the second most important source of each type of social capital. However, there are some anomalies, particularly in relation to influencing change and good leaders, where there were particularly high proportions of ties to ‘unknown’ locations. This reflects the fact that in response to these questions about bridging social capital, egos named alters who they did not necessarily know well enough to know where they lived – politicians, service providers and other public or semi-public figures.

Table 12: Termination points of ego > alter ties, by social capital type (summary)

Type of social capital		Ties terminating in									
		Same area as origin point		Other area within neighbourhood		Outside the neighbourhood		Unknown		Total	
		No.	%	No.	%	No.	%	No.	%	No.	%
Bridging	Influencing change	12	25.5	12	25.5	15	31.9	8	17.0	47	100.0
	Good leaders	16	25.8	9	14.5	23	37.1	14	22.6	62	100.0
Bonding	Socialising	83	30.9	59	21.9	126	46.8	1	0.4	269	100.0
	Personal worries	46	26.3	20	11.4	91	52.0	18	10.3	175	100.0
	Important decisions	38	25.3	23	15.3	86	57.3	3	2.0	150	100.0
	Especially close	5	6.8	5	6.8	64	86.5	0	0.0	74	100.0
Other	Help with tasks	32	26.7	30	25.0	49	40.8	9	7.5	120	100.0
	Ask for \$20	72	35.6	49	24.3	81	40.1	0	0.0	202	100.0

Relationship characteristics

We collected data on four different aspects of egos’ relationships with their named alters: the best description of the relationship between them (e.g. family, friend, colleague?), the length of the relationship, the closeness of it, and the main medium of contact used. For this level of analysis, given the small number of results for some variables, we grouped the social capital into types (as outlined above) according to whether it was bonding or bridging or ‘other’. Headline data, organised by area, is summarised in Table 13 below, and elaborated in the far right column of Table 14.

Table 13: Summary of most common relationship characteristics, all social capital ties, all areas

What was the relationship?	How long had they known each other?	How close were they?	What was their main way of staying in touch?
kin, friends, services	long term	very close	direct, conversational
family 47.3%	5 years + 78.7%	average* 1.6	face-to-face 58.0%
friends 32.3%	10 years + 68.0%	very close 59.1%	talking on phone 24.8%
services 8.7%	20 years + 53.2%	somewhat 23.7%	

*Derived from a five point scale where 1=very close and 5=not close at all.

Table 13: Relationship characteristics (ego > alter) by area

Characteristic	FB		PR		WG		GH		All areas	
	No.	%	No.	%	No.	%	No.	%	No.	%
Type of relationship										
Don't know them	11	5.9	1	0.7	0	0.0	0	0.0	12	1.9
Immediate family	60	32.4	54	37.0	58	34.5	41	30.6	213	33.6
Wider family	26	14.1	15	10.3	33	19.6	13	9.7	87	13.7
Family friend	5	2.7	11	7.5	2	1.2	6	4.5	24	3.8
Close friend	30	16.2	18	12.3	31	18.5	31	23.1	110	17.4
Friend	19	10.3	18	12.3	16	9.5	17	12.7	70	11.1
Neighbour	8	4.3	7	4.8	10	6.0	11	8.2	36	5.7
Colleague	0	0.0	0	0.0	4	2.4	0	0.0	4	0.6
Acquaintance	6	3.2	3	2.1	2	1.2	0	0.0	11	1.7
Service Provider	18	9.7	17	11.6	6	3.6	14	10.4	55	8.7
Unsure	1	0.5	2	1.4	2	1.2	0	0.0	5	0.8
Other	1	0.5	0	0.0	4	2.4	1	0.7	6	0.9
Length of relationship										
Don't know them	14	7.6	3	2.1	2	1.2	2	1.5	21	3.3
Less than one year	5	2.7	9	6.2	3	1.8	6	4.5	23	3.6
One to three years	16	8.6	12	8.2	6	3.6	14	10.4	48	7.6
Three to five years	12	6.5	13	8.9	3	1.8	14	10.4	42	6.6
Five to ten years	14	7.6	18	12.3	19	11.3	17	12.7	68	10.7
Ten to twenty years	16	8.6	21	14.4	39	23.2	18	13.4	94	14.8
Twenty plus years	108	58.4	70	47.9	96	57.1	63	47.0	337	53.2
Closeness										
Don't know them	11	5.9	1	0.7	0	0.0	0	0.0	12	1.9
Very close	113	61.1	80	54.8	98	58.3	83	61.9	374	59.1
Somewhat close	30	16.2	43	29.5	44	26.2	33	24.6	150	23.7
Not sure	1	0.5	6	4.1	2	1.2	5	3.7	14	2.2
Not so close	21	11.4	8	5.5	15	8.9	7	5.2	51	8.1
Not close at all	9	4.9	8	5.5	9	5.4	6	4.5	32	5.1
Main form of contact										
Don't contact	16	8.6	2	1.4	2	1.2	3	2.2	23	3.6
Face to face	105	56.8	93	63.7	108	64.3	61	45.5	367	58.0
Telephone	50	27.0	32	21.9	41	24.4	34	25.4	157	24.8
SMS	2	1.1	9	6.2	0	0.0	26	19.4	37	5.8
Email	1	0.5	0	0.0	0	0.0	1	0.7	2	0.3
Social media	2	1.1	3	2.1	7	4.2	8	6.0	20	3.2
Letter	0	0.0	2	1.4	0	0.0	0	0.0	2	0.3
Haven't recently	5	2.7	3	2.1	8	4.8	0	0.0	16	2.5
Other	4	2.2	2	1.4	2	1.2	1	0.7	9	1.4
TOTAL	185	100.0	146	100.0	168	100.0	134	100.0	633	100.0

In general, the majority of participants' relationships were with immediate family (33.6%), defined as parents, siblings or children, or close friends (17.4%), followed by wider family (13.7%), friends

(11.1%) and service providers (8.7%). This last group included some 'welfare' service providers but also people like GPs and local politicians. Overall, the majority of ties (53.2%) were very long-term (twenty years plus), which probably reflects the dominance of family members among alters. There were few very recently established relationships (just 3.6% were of less than a year's duration). The overwhelming majority of the relationships were described as somewhat or very close (82.8%), and more than half (59.1%) were described as very close. Most people stayed in contact either face-to-face (58.0%) or by speaking on the phone (24.8%). Hardly anyone used email (just two relationships involved this form of communication) and comparatively few participants used SMS (5.8%) or social media (3.2%). These patterns suggest that for our participants, access to social capital involves kin or friends rather than professional or associational ties, although service providers are also important. Relationships are close, long-term and revolve around direct conversation as the primary means of communication.

Within these broad trends, however, there were some variations, across the different study areas and between different types of social capital. (The study area comparisons are also shown above in Table 14 – cells shaded in grey are those directly referred to in this and preceding discussion.) Relationships in Forest Bay were comparatively longer-term (58.4% were of 20 years' plus duration, compared to 53.2% for all areas), but also included a greater proportion of ties described as being either 'not so close' or 'not close at all' (16.3% in total, compared to 13.2% for all areas). Participants from Park Rise were slightly less likely to name close friends in relation to sources of social capital (12.3%, compared to 17.4% for all areas), and their relationships overall were somewhat shorter-term and less close (47.9% of their relationships were of 20 years or more duration, compared to 53.2% for all areas, and 54.8% were considered very close, compared to 59.1% for all areas). Contact between egos and alters was also more likely to be face-to-face for Park Rise participants (63.7% compared with 58% for all areas). Participants from Woodland Grove described relationships that were much more family-centred (54.1% were with immediate or wider family, compared with 47.3% for all areas). These relationships were longer-term (91.6% of Woodland Grove's ego-to-alter relationships had lasted for five years or more, and 80.3% for ten years or more, compared to corresponding figures for all areas of 78.7% and 68.0% respectively), and they also involved more face to face contact (64.3%). In Grass Hill, by contrast, more social capital seemed to be accessed through friendships (40.3% were with close friends, friends and family friends, compared to 32.3% for all areas), relationships were comparatively shorter (33.5% had lasted between one and ten years, compared to 24.9% for all areas), and there was less face-to-face contact (45.5%) and more use of SMS (19.4%, compared to 5% for all areas) as the primary mode of contact. The latter figure may be connected to the fact that Grass Hill participants were the youngest cohort in the sample (see Table P2, Appendix 2).

The analysis above (see Tables 7 and 11 and Figures 5 and 6), showed that there was an extensive reliance on ties with people living outside the area for all forms of social capital. This appears, superficially at least, to contradict the established wisdom about relational ties in disadvantaged areas being proximate, close and strong in character, and rather supports Blokland's view that ties are increasingly becoming disembedded from place (Blokland 2003). Compared to alters living inside the area or in unknown locations, alters living outside the area were more likely to be classified as immediate family or close friends (for figures, see Table R10, Appendix 2). A greater proportion of the relationships were very long term (i.e. 20 years plus) and very close. Understandably, the proportion of relationships where the main form of contact was face-to-face was lower among alters living outside the area than the other alters, but the use of

the other form of 'direct' contact, speaking on the telephone, was proportionally higher. All of this suggests that people's social capital relationships with those outside the area are founded on close kin and friends, rather than associational or professional ties. And while it is the case that distances in the Tasmanian context are not as great as they are in many other parts of Australia, which means that 'outside the area' might not be as inaccessible as it would be in other contexts, the extensive difficulties participants experienced in relation to transport services (section 'Connections with Services', below) suggests that in practice, there would be difficulties involved in meeting face-to-face.

Table 15: Relationship characteristics (ego > alter) by type of social capital

Characteristic	Bridging		Bonding		Help with tasks		Ask for \$20		All social capital		
	No.	%	No.	%	No.	%	No.	%	No.	%	
Type of relationship											
Don't know them	1	1.0	10	2.2	2	1.6	2	1.0	12	1.9	
Immediate family	14	14.1	178	38.4	44	34.6	102	50.5	213	33.6	
Wider family	7	7.1	60	13.0	19	15.0	25	12.4	87	13.7	
Family friend	2	2.0	20	4.3	6	4.7	16	7.9	24	3.8	
Close friend	14	14.1	95	20.5	13	10.2	32	15.8	110	17.4	
Friend	17	17.2	53	11.4	7	5.5	13	6.4	70	11.1	
Neighbour	4	4.0	18	3.9	11	8.7	12	5.9	36	5.7	
Colleague	4	4.0	1	0.2	0	0.0	0	0.0	4	0.6	
Acquaintance	8	8.1	1	0.2	2	1.6	0	0.0	11	1.7	
Service Provider	19	19.2	26	5.6	22	17.3	0	0.0	55	8.7	
Unsure	4	4.0	0	0.0	1	0.8	0	0.0	5	0.8	
Other	5	5.1	1	0.2	0	0.0	0	0.0	6	0.9	
Length of relationship											
Don't know them	5	5.1	11	2.4	6	4.7	2	1.0	21	3.3	
Less than one year	4	4.0	12	2.6	9	7.1	4	2.0	23	3.6	
One to three years	15	15.2	30	6.5	10	7.9	7	3.5	48	7.6	
Three to five years	11	11.1	32	6.9	12	9.4	8	4.0	42	6.6	
Five to ten years	11	11.1	47	10.2	10	7.9	20	9.9	68	10.7	
Ten to twenty years	18	18.2	63	13.6	14	11.0	26	12.9	94	14.8	
Twenty plus years	35	35.4	268	57.9	59	46.5	135	66.8	337	53.2	
Closeness											
Don't know them	1	1.0	10	2.2	2	1.6	2	1.0	12	1.9	
Very close	34	34.3	320	69.1	72	56.7	152	75.2	374	59.1	
Somewhat close	23	23.2	98	21.2	23	18.1	40	19.8	150	23.7	
Not sure	5	5.1	8	1.7	2	1.6	2	1.0	14	2.2	
Not so close	21	21.2	18	3.9	12	9.4	6	3.0	51	8.1	
Not close at all	15	15.2	9	1.9	9	7.1	0	0.0	32	5.1	
Main form of contact											
Don't contact	8	8.1	11	2.4	5	3.9	2	1.0	23	3.6	
Face to face	49	49.5	273	59.0	82	64.6	138	68.3	367	58.0	
Telephone	20	20.2	126	27.2	20	15.7	44	21.8	157	24.8	
SMS	1	1.0	32	6.9	9	7.1	13	6.4	37	5.8	
Email	0	0.0	2	0.4	0	0.0	0	0.0	2	0.3	
Social media	4	4.0	12	2.6	1	0.8	4	2.0	20	3.2	
Letter	1	1.0	0	0.0	1	0.8	0	0.0	2	0.3	

Haven't recently	12	12.1	3	0.6	0	0.0	1	0.5	16	2.5
Other	4	4.0	4	0.9	2	1.6	0	0.0	9	1.4
TOTAL	99	100.0	463	100.0	120	100.0	202	100.0	633	100.0

There were also differences in relationship characteristics across the different types of social capital (see Table 15 above). Bridging ties, unsurprisingly, were less likely to involve family (21.2% compared to 47.3% for all types of social capital), and these relationships were shorter (only 35.4% were of 20 years' plus duration compared to 53.2% of all ties), less close (36.4% were classified as not so close or not close at all, compared to only 13.2% of all ties) and involved less direct or conversational contact (69.7% involved face-to-face or telephone contact, but this compared to 82.8% for all ties; 12.1% of bridging ties involved no recent contact and 8.1% involved no contact at all).

For 'help with tasks', as distinct from all types of social capital (see far right column in Table 15), participants were drawing primarily on family (49.6%) or service providers (17.3%) rather than friends (who accounted for only 20.4% of 'help with tasks' ties), and these relationships involved higher levels of face-to-face contact (64.6% compared to 58.0%). As discussed above, we had initially been uncertain about how to classify the form of social capital represented by 'ask for \$20'. The analysis showed that the characteristics of these relationships were much more consistent with those of bonding ties than they were with bridging or 'help with tasks' ties – relationships in which egos feel they can ask for small amounts of money if they need it are concentrated around immediate family (50.5%), as well as wider family (12.4%) and close friends (15.8%), are longer-term (66.8% had lasted for 20 years or more) and closer overall (95.0% are somewhat or very close, with the over three quarters of those being very close), and involve more direct forms of contact (i.e. face-to-face or talking on the phone) (90.1). Bonding ties are likewise generally closer (69.1%), longer-term (57.9% were of twenty years or more duration) and mainly involve family and friends (51.4% family, compared to 47.3%, and 36.2% friends), compared to the figures for all types of social capital overall.

In addition to these general comparisons, we undertook more detailed comparative analysis of relationship characteristics across the different forms of social capital and the different study areas, with a particular focus on deviations from both the pattern for the area and the pattern for the types of social capital. This work identified some further points of interest:

- First, participants in the areas which the service providers consulted about site selection had identified as 'stigmatised' were more likely to classify their bridging social capital ties as service providers (27.8% in Park Rise and 33.3% in Grass Hill, compared to 19.2% overall), while those in the 'non-stigmatised' areas are more likely to identify them as friends or close friends (39.3% in Forest Bay and 38.4% in Woodland Grove, compared to 16.7% and 2% respectively for Park Rise and Grass Hill) or other types of associational relationships such as colleagues (Woodland Grove, 15.4%) or acquaintances (Forest Bay, 14.3%). This suggests that participants in the non-stigmatised areas are more likely to be drawing on personal social capital rather than generic forms for access to influence or leadership (for full figures, see Table R3, Appendix 2).
- Second, 'help with tasks' relationships were quite heterogeneous with respect to relationship type, form of contact and closeness (for figures, see Table R11, Appendix 2). Given this

greater level of diversity, further analysis was conducted to identify any patterns that did exist within these relationships. This additional analysis identified three approximate groupings within the 'help with tasks' relationships. The differences appeared contingent on the degree to which the relationship was a source of more than one type of social capital (see Table 11 above). Although caution needs to be used in assessing these results as the numbers involved are relatively small and the number of participants involved is even smaller, these groupings were nonetheless reasonably distinct and are worth noting here because it gives greater insight into the quality and content of these social interactions.

□ **Group 1: People named as helping with tasks and as preferred socialising relationships**

This group was a mix of family, friends and neighbours. Many of the relationships were long-term and very close, but a reasonable number were shorter term and described as somewhat close, not so close or even not close at all. Most of the contact was face-to-face.

□ **Group 2: People named as helping with tasks and in relation to one or more other indicators of social capital (excluding those in group 1)**

This group was dominated by immediate family, although there were also a number of wider family members, family friends, other friends and neighbours. Most of these relationships were very long-term and described as very close. Again, most of the contact was face-to-face.

□ **Group 3: People named only for helping with tasks, and not for other indicators of social capital**

This group was more diverse, including family, service providers and neighbours, as well as a small number of friends. There were long-term and close relationships, especially with family, but this group also included many of the shorter-term relationships and those described as less close. These relationships were mainly face-to-face as well. Within this group, Grass Hill participants did stand out – they tended to be the only participants to name ‘helping with tasks’ alters in relation to bridging social capital as well, and their relationships fell into a more diverse range of categories, including close friends and neighbours.

- Third, there was a strikingly consistent picture across the ‘ask for \$20’ relationships. Although there were some variations between the four areas in terms of the relative proportions (see Table R12, Appendix 2), the distribution patterns were remarkably consistent.
- Fourth, the aggregate figures did conceal some differences. As noted above, compared to the other areas, the relationships of participants from Forest Bay seemed to be less close. However, on closer inspection, this seemed to be an effect of the inclusion of bridging relationships – other forms of relationship in this area were characterised by greater levels of closeness (see Table R9, Appendix 2). Similarly, the overall pattern in Woodland Grove of more family and closer, more direct forms of contact also concealed some marked differences in relation to bridging social capital and help with tasks. Bridging ties were not with family, but almost exclusively with friends, neighbours, colleagues and other, non-family groups, and the proportion of shorter-term relationships (10 years’ duration or less) was more than double what it was for Woodland Grove as a whole. Bridging ties were also much less close, with an average closeness of 3.23¹⁰; 57.7% of relationships were described as not so close or not close at all. Just over a third (34.6%) did not involve current contact (meaning that participants indicated that either this was someone they did not contact or was someone they had not been in touch with for some time). Relationships providing ‘help with tasks’ were also distributed differently across the categories in Woodland Grove. Compared to just 3.6% across all forms of social capital for Woodland Grove, 27.3% of ‘help with tasks’ relationships were with service providers, and although ‘help with tasks’ relationships had comparable

¹⁰ Derived from a five point scale where 1=very close and 5=not close at all.

longevity to the others in the area, they tended to be somewhat less close (an average of 1.92 compared to 1.35 and 1.37 for bonding and ‘ask for \$20’ ties) (see Table R13, Appendix 2).

- Fifth, the presence of neighbours as sources of bonding social capital, ‘help with tasks’ and ‘ask for \$20’ was only really notable in Grass Hill. When figures were aggregated for all four areas, neighbours only accounted for 3.9% of bonding ties (n=18), 8.7% of ‘help with tasks’ ties (n=11) and 5.9% of ‘ask for \$20’ ties (n=12). But in Grass Hill, those figures were 7.0% (n=7), 12.9% (n=4) and 11.4% (n=5) respectively. Grass Hill relationships, as noted above, also featured in general a more diverse spread of relationship lengths and types of contact (see Table R14, Appendix 2).

Connections with services

A large section of the survey concerned participants’ use of and relationship with services in the neighbourhood. There are more than 400 programs operating in the neighbourhood, yet in the last decade, the suburb’s ranking on various measures of poverty and disadvantage has worsened (Vinson & Rawsthorne 2015). Given the level of investment from community organisations and government in the area, the residents’ use of these services is of clear interest to policy-makers. However, the principal finding from our research is that residents do not engage with very many services at all. In the survey, participants were asked about their engagement with local services – specifically, if they used these services, and if they did not, was this because they did not need them or because of some other reason to do with access, unhelpful staff or another barrier. Table 16, below, shows the proportions of participants in each area who said they used the services, and the proportions who said they needed the service, but didn’t use it (for those who did not use the service because they did not think they needed it see Table C1, Appendix 2).

Table 16: Take up of local services, by area

Service type	FB % (n=26)		PR % (n=25)		WG % (n=25*)		GH % (n=25)	
	Use	Don't use**	Use	Don't use	Use	Don't use	Use	Don't use
Aboriginal	7.7	3.8	20.0	4.0	12.0	4.0	12.0	0.0
Abuse & assault	0.0	0.0	0.0	8.0	0.0	0.0	8.0	4.0
Education	11.5	0.0	12.0	8.0	12.0	8.0	32.0	16.0
Employment	15.4	3.8	16.0	4.0	24.0	12.0	20.0	12.0
Emergency relief	11.5	3.8	32.0	0.0	24.0	0.0	36.0	4.0
Financial help	3.8	0.0	12.0	0.0	16.0	0.0	12.0	4.0
Gambling	0.0	0.0	4.0	0.0	0.0	0.0	0.0	0.0
Legal & advocacy	7.7	3.8	20.0	20.0	8.0	8.0	20.0	4.0
Medical	30.8	38.5	56.0	40.0	52.0	36.0	36.0	36.0
Mental health	11.5	0.0	8.0	8.0	20.0	0.0	24.0	4.0
Migrant	0.0	0.0	0.0	0.0	0.0	0.0	0.0	0.0
Sporting clubs	3.8	3.8	8.0	4.0	12.0	0.0	12.0	4.0
Housing	50.0	0.0	60.0	12.0	52.0	8.0	48.0	8.0
Support & self help	7.7	0.0	0.0	0.0	4.0	0.0	4.0	8.0
Alcohol & drugs	0.0	3.8	16.0	0.0	0.0	4.0	0.0	0.0
Local	42.3	3.8	64.0	0.0	68.0	0.0	32.0	12.0

government								
Children's	11.5	0.0	16.0	0.0	12.0	0.0	8.0	8.0
Religious	0.0	0.0	4.0	0.0	4.0	0.0	4.0	4.0
Library, PCYC etc.	50.0	3.8	52.0	12.0	60.0	0.0	48.0	0.0
General welfare	11.5	3.8	24.0	4.0	28.0	0.0	24.0	8.0
Counselling	11.5	0.0	20.0	4.0	16.0	4.0	16.0	4.0
<p>* Data for this question was missing for one participant in this area, so she was excluded from analysis. ***'Don't use' includes: hard to access, staff are unfriendly, don't provide what I need and 'other'. All other participants who responded said they did not use the service because they did not need it (see Table C1 Appendix 2).</p>								

With the exception of medical services, housing services, local government services, the local library and PCYC and some use of general welfare and counselling services, participants did not use local services, and in the majority of cases, this was because they did not believe they needed them. The exceptions were partly explained by the nature of the sample (particularly with respect to the high proportion of social housing tenants) or by the way participants interpreted the labels. For example, the larger number using council services is possibly because a number of participants interpreted this to mean their use of services like rubbish collection.

Medical services were the only type of services that participants consistently identified as needing, but being unable to access within the neighbourhood. The section of the survey on service use included an open-ended question about reasons for not using local services – in total, this generated 115 pieces of information from 63 of the 102 participants. Half of this information related to medical services. This may be because, as the data collection progressed and we became aware of medical services as an issue, we sought to collect as much information about the situation as we could. However, this does not diminish the validity of what the participants had to say. Out of 57 comments, 26 of them (45.6%) related to difficulties in accessing the local doctor. The practice had closed its books and was not accepting new patients. Even those participants who were on the books were unable to obtain appointments quickly – there were nine references to waiting times of up to two weeks even if the problem was urgent. Lack of use was not related to the quality of the service on offer – in fact only four participants said something negative about this. In some cases it was a matter of preference; 13 participants said that they were using an out-of-area doctor because they wanted to preserve continuity of care with a practitioner they had seen prior to moving into the neighbourhood (n=9) or who had previously been based at the local practice but had now moved elsewhere (n=4). The importance placed on continuity of care can be read against the references by two of the participants to the very high turnover among practitioners in the local practice, something confirmed anecdotally by other people in the area. For six participants, difficulties in accessing medical services were compounded by problems with transport. Two participants actually said they went to an out-of-area doctor because, from a transport perspective, it was easier than getting to the local one.

Apart from medical services, other service types that came in for criticism from participants included the lack of help from local employment services (n=6), the lack of interest shown by the council (n=4), the advice-only focus of the local legal service (n=6) and housing services (n=11). Participants also complained about a general lack of information about what was available in the community (n=8) – and in addition to this, during the data collection, all of the interviewers

frequently had the experience of asking participants if they used a particular service in the area only to have the participant express surprise that such a service existed.

A further open-ended question asked participants if there were any service gaps. Of the 102 participants, 64 participants supplied 92 pieces of information about what they thought was missing in the area. When coded into categories, three main areas of deficit emerged. Unsurprisingly given the information obtained about problems with the local medical practice, the difficulties in accessing doctors (n=12) ranked highly. So did the lack of commercial services in the area (n=12 – receiving more than one mention in this category were banks, shops other than supermarkets and takeaways). Problems with the bus service were identified by just five participants, but it is worth noting that midway through our data collection the operator, Metro Tasmania, changed its timetable, rationalising services in the area, and several of the comments related to difficulties that had been caused by this. However, the most consistently identified service gap was with respect to recreational opportunities for children and young people (n=29). The lack of things to do for young people was seen as a cause of significant problems in the area, including general boredom, inappropriate recreational activities like riding motocross bikes through the streets, and petty crime. Smaller children were not excluded, as the need for better maintained, cleaner and more plentiful playgrounds was identified by five participants, and a number of others mentioned the need for more family facilities including parks.

The final question relating to services asked participants whether, if support was made available to help them in a given area of their life, they would use it. Responses are shown in Table 17 below.

Table 17: Proportion of participants interested in additional support services, by area

Service type	Proportion of participants expressing interest			
	FB % (n=26)	PR % (n=25)	WG* % (n=25)	GH % (n=25)
Education & training	26.9	40.0	56.0	64.0
Finding employment	26.9	28.0	48.0	40.0
Leisure activities	34.6	56.0	64.0	72.0
Managing money	19.2	8.0	28.0	28.0
Filling in forms	26.9	24.0	12.0	28.0
Legal issues	26.9	16.0	40.0	44.0
Parenting skills	7.7	8.0	12.0	8.0
Household management skills	7.7	0.0	12.0	20.0
Using fewer drugs and/or alcohol	0.0	4.0	8.0	4.0
Reducing or quitting smoking	19.2	8.0	40.0	60.0
Making friends	11.5	24.0	36.0	36.0
Average	18.9	19.6	32.4	36.7
*Data for this question was missing for one participant in this area, so she was excluded from analysis.				

The table shows that in general, participants were disinterested in additional support services. This was despite the fact that relatively few participants were already using extra support in these areas (see Table C2, Appendix 2). From area to area, the most interest in additional services was shown in Grass Hill, followed by Woodland Grove. This aligns with the geographical distribution

of services in the neighbourhood, most of which have their offices in Forest Bay or Park Rise. In terms of service types, the most interest was shown in relation to education and training, finding employment and leisure activities. Participants in Woodland Grove and Grass Hill also registered some interest in help with legal issues and with quitting smoking. Managing money, support with filling out forms and help making friends also attracted a small amount of interest. In general, as responses to the other service-related questions indicate, the principal problems with services in the area relate not to welfare and social support provision, which is ample, but to other areas of social infrastructure, such as health care, transport and recreational opportunities.

Limitations

This study is a social network analysis of a highly stigmatised neighbourhood in an urban area of Hobart, Tasmania. While the study neighbourhood may resonate with other similarly disadvantaged places in Australia, there is great scope to refine and continue to develop particularly the SNA tool towards better understanding relational network and social capital ties between residents in disadvantaged (and other) neighbourhoods, and how this may relate to stigma. As Crisp (2013: 336) rightly notes, social dynamics can vary notably between similarly disadvantaged neighbourhoods and thus no universal conceptions of relational tie characteristics is likely. For example, it is not reasonable in this small-scale study to generalise from the finding of a correlation between patterns of social ties and greater stigma as cause and consequence cannot be disentangled due to the multiple and complex factors involved in the production of disadvantage. However, further SNA work of this kind may help answer whether the correlation between stigma and fewer intra-neighbourhood (i.e. inter-area) ties identified here is also found in other contexts. A deeper understanding of the issues that compound the development of social ties (or lack thereof), including the neighbourhood histories and social processes underlying them, might also help account for these patterns. Other factors also requiring further investigation include whether the significant difference across the neighbourhood between perceived and actual relationship ties is common in other stigmatised neighbourhoods. The use of SNA provides insights in this case that, extrapolated to other populations, would be an exciting research step towards understanding patterns of relationship ties difficult to otherwise capture through routine survey and interview methods.

Discussion

Our initial selection of the four study sites within the neighbourhood was based on a tacit assumption that we were selecting two areas that fitted one set of criteria and two areas that fitted another, and that in our analysis, we would find differences based on these criteria. However, what we have found is that there were some common themes across all four areas, and conversely, that each of the four areas is also distinctive.

One of the key findings common to the four areas was that despite the fact that some had comparatively larger networks than others, the actual networks participants across all four areas reported were very small. Their perceived ties — their ‘imagined’ communities — were some three times their actual (named) ties. This observation does not negate the experience of an ‘imagined’ community as invalid or deluded (Blokland 2003). What it does do is establish substantive distinction between who neighbours ‘know’ (to recognise, to talk to), and who neighbours ‘know’ (to support, collaborate with, help, ask from, socialise with etc — or in a bonding/bridging social capital sense). This is in part the difference between what people ‘feel’ and what they ‘do’ (Agampodi et al. 2015), and building on this, our data may suggest that the extent to which participants ‘do’ (enact) relationships of social capital may be less dynamic than their sense, values and beliefs (feelings) about enacting social capital.

Further, commonalities in the nature of social relationships across all areas included sourcing social capital of various kinds from people they considered themselves very close to, had known a very long time, preferred to communicate with face to face, and were either related to or shared close friendships with. Notably however, these relationships were not primarily local relationships — up to half of all ties were with people living outside the neighbourhood. And where ties were external, participants still largely preferred personalised and non-technical communication (face to face or speaking via telephone). The preferred type of social capital drawn on in their relationships was bonding ties (particularly socialising and asking for \$20), with far fewer bridging relationships acknowledged in response to the name generators. Taken together, the small network sizes, the close personalised, bonding social capital preferences and significance of non-neighbourhood ties does in part problematise literature arguing that disadvantaged communities are characterised by evidence of strong, localised forms of (mostly bonding) social capital. The data certainly corroborates with literature regarding evidence of higher levels of bonding social capital. However, it also suggests that Blokland’s (2003) account of neighbourly relations increasingly becoming disembedded from place of residence, or ‘privatised’, through residents choosing more carefully to spend time with closer family and intimate friends rather than with general acquaintances and neighbours, has some credence here.

The low level of local service utilisation corroborates the data on bridging social capital, or lack of ‘resource generation’ capability (Crossley et al. 2015). Despite the very large number of services available in the area, people made relatively little use of them, and this was primarily because they did not think they needed them. The service gaps identified were primarily related to medical services, commercial services (such as shops and banking), public transport and, overwhelmingly, the recreational needs of children and young people. In relation to the provision of additional services, the general reaction was one of disinterest. This low level of bridging social capital in the neighbourhood supports the findings of other research, but the perceived lack of need for more is worth noting.

Recent research investigating the association between service provider and service user relationships in the context of disadvantage and stigmatisation finds that stigmatisation undermines the process of developing shared identity in a corrosive interplay that can result in disengagement between the two groups. Stigma consciousness creates negative 'coping' or disengagement strategies amongst service users, which, when unacknowledged by service providers, serves to deepen any stigmatising stereotypes they may carry and create antagonisms leading to 'conflict escalation' (Stevenson et al 2014). This dynamic may be further exacerbated in a context where service providers largely serve residents within a bounded geographical area in which they most likely do not reside themselves, as in the case of our four areas. Consequently, it is worth noting that the general disinterest in engaging in services by participants in this study may be indicative of service-user dynamics found more generally in disadvantaged communities.

Turning from commonalities to the distinctiveness of each of the four areas, two dimensions should be noted. First, the differences between the four areas were reflected in the data collected on stigmatisation. Although participants' perception of outsiders' views was that the whole neighbourhood was marked out as problematic and dysfunctional (and there is ample evidence in Tasmanian popular discourse to confirm this), at an intra-neighbourhood level, there were clear patterns in the way in which participants viewed themselves and their own area as distinct from other locations in the neighbourhood. Notably, Woodland Grove was singled out by participants from other areas as the 'problem', a perception that Woodland Grove participants themselves reflected back in the survey. Wacquant's 'territorial stigmatisation' is here enacted as an 'intra-territorial stigmatisation' with the five processes (2014:1273-5) focussed *inward* toward Woodland Grove in a micro-simulation of the broader stigmatisation of the neighbourhood as a whole. That is, Woodland Grove was noted as having the most poverty and crime (e.g. 'dangerous', full of 'drugs and speed', or 'stealing' and 'burnt-out cars'). It was the subject of consensus as the place people 'never go' and the area media would likely blame for criminal behaviours. It conjured images of disorganisation ('getting beyond a joke out there'), elicited fictionalised or sensationalised language (e.g. 'the dark side', 'scary', or 'where the housing department dumped all the idiots'), and evoked dark, penal responses to its marginality ('life and death', 'never make friends from there', 'put a black mark on people'). This 'denigration of place' is not just a 'novel urban phenomenon', but becomes concrete when a collective representation becomes fixated on place (Wacquant et al. 2014:1278). We return to this point in the conclusion.

Second, the social network analysis revealed clear distinctions in the ego-networks of participants from area to area. Comparatively, Forest Bay participants had larger networks in both actual and effective terms, and were able to exercise influence and act with the least constraint. In Park Rise, participants had less dense networks than average, but the lowest effective size. In Woodland Grove, the networks were dense and strong and thus participants were positioned with less capacity to exert influence and under the greatest constraint. In Grass Hill, participants had the smallest, least dense and weakest networks. This quantitative data was reinforced by the analysis which examined ties by area of origin and destination. It found that Woodland Grove and Grass Hill were the most isolated of the four areas, but that Woodland Grove had more internal social capital. Connections beyond the neighbourhood were important sources of social capital for all the areas, but when alter to alter ties were incorporated into the analysis, it became evident that while Forest Bay, Park Rise and Woodland Grove all had a similar flow of connections in as they had out, Grass Hill's connections from outside the neighbourhood as a whole were much more minimal, reinforcing Grass Hill's isolation in comparison to the other four areas.

From this data, we can conclude that Woodland Grove participants had the strongest and densest networks. These participants, on average, had lived longer in the area and in their dwelling than participants from other areas, and compared to the other participants, they had higher levels of education and labour market engagement. Their relationships were characterised, more so than the participants in other areas, by relationships with immediate family and close friends, very long tie duration, high levels of closeness and high levels of face to face contact. The data also indicates that Woodland Grove participants' relational ties are either highly internalised (i.e. with other people who also live in Woodland Grove) or externalised beyond the neighbourhood itself. Woodland Grove thus demonstrates a level of neighbourhood introversion distinct from the other areas.

Conclusion

The purpose of our project is to map social and relational networks in order to build on our understanding of the processes of stigma (re)production and mitigation. Touraine (2000) argues that the process of stigmatisation can cause communities to become introverted, effectively functioning as a process of ghettoisation. Our research highlights that this introversion is not limited to reactions to perceptions of a 'bad area' from outside, but continues, in a kind of 'micro-process of introversion', into the topography of the area itself — an 'intra-territorial stigmatisation', focussed in this case on Woodland Grove. While our data supports Warr's (2005a, p. 8) point that the 'unsympathetic attitudes and actions of outsiders' add to the challenges of living in a stigmatised neighbourhood, it also suggests that intra-neighbourhood stigma — the 'unsympathetic attitudes and actions' of outside-insiders — perpetuates the social and spatial divisions that already exist because of external stigmatisation.

This is a form of 'othering' (Crisp 2013) well recognised in stigmatisation literature per se but not understood as well in relation to intra-territorial or intra-neighbourhood stigma. Further, unlike other studies, which attribute intra-neighbourhood stigma to situations where middle class residents in an area resent and reject social housing tenants or other low income groups, our research has found that stigma is correlated less with socio-economic differences and more to the number and type of social ties within the neighbourhood. In the case of Woodland Grove, relative intra-neighbourhood isolation and internal density (or less capacity to exert influence beyond the area) contributes to a self-perpetuation of neighbourhood divisions, providing fewer reasons to engage and greater reason to internalise the Chinese whispers and dark urban legends relegating one place as a scapegoat for the rest. In this sense '...stigma is more than simply the presence of a negative group stereotype: it is an active, corrosive process that undermines relations between communities' (Stevenson et al., 2014: 465).

Thus, our findings show both empirically and specifically that social space *is* 'roughly superimposed' (Bourdieu 1999, p. 125) upon physical space, and this results in intricate entanglements of power (Sharp et al. 2000). This knowledge provides a unique lens for understanding disadvantaged urban places, particularly when laying the foundation for community development strategies to address disadvantage and stigma. In particular, we stress the need for supporting the identification of entry and re-entry points for building relationships across and between the micro-territories that are most and least at risk of internal stigmatisation. Without them for example, community development strategies may (unintentionally) continue to deepen internal stigmatisation by continuing to build relational capital *within* rather than *between* the spaces where representational struggles are fought (Harvey 1996). Strategies can thus be

used to repair spatial and relational fragmentation by building collaborative relationships across individuals and organisations, particularly focusing on those who have become isolated or 'districts of relegation' (Wacquant 2016) within their wider urban territory. To address these internal divisions will deepen our conceptualisation of how everyday social practices and (symbolic) performances converge with spatial geography and topography to heal social divides.

References

Abbasi, A., Wigand, R. T., & Hossain, L. (2014) Measuring social capital through network analysis and its influence on individual performance. *Library & Information Science Research*, 36(1), 66-73.

ABS (Australian Bureau of Statistics) (2013), *2011 Census QuickStats: Bridgewater-Gagebrook Code 601011001 (SA2)*, ABS, Canberra, <http://www.censusdata.abs.gov.au/census_services/getproduct/census/2011/quickstat/601011001?opendocument&navpos=220>, accessed 27 June 2016.

Agampodi, T. C., Agampodi, S. B., Glozier, N., & Siribaddana, S. (2015) Measurement of social capital in relation to health in low and middle income countries (LMIC): A systematic review. *Social Science & Medicine*, 128, 95-104.

Arthurson, K. (2010) Operationalising Social Mix: Spatial Scale, Lifestyle and Stigma as Mediating Points in Resident Interaction. *Urban Policy and Research*, 28(1), 49-63.

Arthurson, K. (2013) Mixed tenure communities and the effects on neighbourhood reputation and stigma: Residents' experiences from within. *Cities*, 35, 432-438.

Atkinson, R., & Jacobs, K. (2008) *Public Housing in Australia: Stigma, Home and Opportunity*. University of Tasmania: Housing and Community Research Unit (HACRU).

Berkman, L. F., & Syme, S. L. (1979) Social networks, host resistance, and mortality: a nine-year follow-up study of Alameda County residents. *American journal of Epidemiology*, 109(2), 186-204.

Blokland T, (2003) *Urban Bonds*. Polity Press: Cambridge.

Borgatti, S.P. (2002) NetDraw: Graph Visualization Software. Harvard: Analytic Technologies.

Borgatti, S.P., Everett, M.G. and Freeman, L.C. (2002) UCINET 6 for Windows: Software for Social Network Analysis. Harvard, MA: Analytic Technologies.

Bourdieu, P (1986) The Forms of Capital, in *Handbook of Theory and Research for the Sociology of Education*, ed. J Richardson, trans. Richard Nice. New York: Greenwood.

Bourdieu, P. (2011) The forms of capital. (1986). *Cultural theory: An anthology*, 81-93.

Burbidge, A. (1998) Changing patterns of social exchanges: issues in the literature. *Family Matters*, (50) 10.

Burcher, M., & Whelan, C. (2015) Social network analysis and small group 'dark' networks: an analysis of the London bombers and the problem of 'fuzzy' boundaries. *Global Crime*, 16(2), 104.

Burt, RS (1992) *Structural holes: the social structure of competition*, Harvard University Press: Cambridge.

Burt, R. S. (1993) The social structure of competition. *Explorations in economic sociology*, 65, 103.

Carolan, B. V. (2014) *Social Network Analysis Education: Theory, Methods & Applications*. SAGE Publications, Inc: Thousand Oaks, CA.

- Cheshire, L., & Zappia, G. (2015) Destination dumping ground: The convergence of 'unwanted' populations in disadvantaged city areas. *Urban Studies*. DOI: 10.1177/0042098015587241. 1-18.
- Crisp, R. (2013) 'Communities with oomph'? Exploring the potential for stronger social ties to revitalise disadvantaged neighbourhoods. *Environment and Planning C: Government and Policy*, 31(2), 324-339.
- Crossley, N., Bellotti, E., Edwards, G., Everett, M. G., Koskinen, J., & Tranmer, M. (2015) *Social network analysis for ego-nets: Social network analysis for actor-centred networks*. Sage.
- DHHS (Department of Health & Human Services) (2010) *Bridgewater Gagebrook Housing Regeneration Master Plan*. Report to DHHS prepared by Aurecon.
- De Silva, M. J., Huttly, S. R., Harpham, T., & Kenward, M. G. (2007) Social capital and mental health: a comparative analysis of four low income countries. *Social Science & Medicine*, 64(1), 5-20.
- Ennis, G., & West, D. (2010) Exploring the Potential of Social Network Analysis in Asset-based Community Development Practice and Research. *Australian Social Work*, 63(4), 404-417.
- Ezzy, D. (2000) Illness narratives: time, hope and HIV. *Social science & medicine*, 50(5), 605-617.
- Flanagan, K (2015a), 'A genealogy of public housing production: practice, knowledge and the broadacre housing estate', *Housing, Theory and Society*, vol. 32, no. 4, pp. 407-428.
- Flanagan, K (2015b) *Ordinary things: an archaeology of public housing*. PhD thesis. University of Tasmania.
- Giordano, G. N., & Lindstrom, M. (2010) The impact of changes in different aspects of social capital and material conditions on self-rated health over time: a longitudinal cohort study. *Social Science & Medicine*, 70(5), 700-710.
- Gittell, R., & Vidal, A. (1998) *Community organizing: Building social capital as a development strategy*. Sage publications.
- Goffman, E. (1963) *Stigma: Notes on the Management of Spoiled Identity*. New York: Simon & Schuster, Inc.
- Grey, F. (2008) Benevolent othering: displaying and "celebrating" diversity. Paper presented to TASA conference, 2-5 December, Melbourne.
- Grootaert, C., Narayan, D., Nyhan Jones, V., & Woolcock, M. (2004) *Measuring social capital: An integrated questionnaire*. Washington, DC: The World Bank.
- Harpham, T., Grant, E., & Thomas, E. (2002) Measuring social capital within health surveys: key issues. *Health Policy and Planning*, 17(1), 106-111. <http://dote.org.au/findings/tasmania/>
- Hurtado, D., Kawachi, I., & Sudarsky, J. (2011) Social capital and self-rated health in Colombia: The good, the bad and the ugly. *Social Science & Medicine*, 72(4), 584-590.

- Jacobs, K., & Flanagan, K. (2013) Public housing and the politics of stigma. *Australian Journal of Social Issues*, 48(3), 319-337,271-272.
- Jacobs, K., Arthurson, K., & Randolph, B. (2005). *Developing appropriate exit strategies for housing regeneration programmes*. AHURI Final Report No.87. Australian Housing and Urban Research Institute.
- Jacobs, K., Arthurson, K., Cica, N., Greenwood, A., & Hastings, A. (2011) *The stigmatisation of social housing: findings from a panel investigation*. AHURI Final Report No.166. Australian and Urban Research Institute.
- Kikuchi, M., & Coleman, C. L. (2012) Explicating and measuring social relationships in social capital research. *Communication theory*, 22(2), 187-203.
- Krebs, V. (2008) *Social network analysis, a brief introduction*. Retrieved 27.06.2016.
- Link, B. G., & Phelan, J. C. (2001) Conceptualizing stigma. *Annual review of Sociology*, 363-385.
- Martin, J. I. (1967) Extended Kinship Ties: An Adelaide Study. *Australian & New Zealand Journal of Sociology*, 3(1), 44-63.
- Mathie, A. & Cunningham, G. (2003), From clients to citizens: asset-based community development as a strategy for community-driven development. *Development in Practice*, 13(5), 474-486.
- McCallister, L., & Fischer, C. S. (1978) A Procedure for Surveying Personal Networks. *Sociological Methods & Research*, 7(2), 131-148.
- McCulloh, Ian; Armstrong, Helen; Johnson, Anthony (2013) *Social Network Analysis with Applications*. Retrieved from <http://www.ebib.com>
- McDonald, K. (1999) *Struggles for subjectivity: Identity, action and youth experience*: Cambridge University Press.
- Narayan-Parker, D. (1999) *Bonds and bridges: Social capital and poverty* v2167. World Bank Publications.
- Norton, A (1997) Social capital and civil society: some definitional issues, in *Social capital: the individual, civil society and the state*, Policy forum no. 14, Centre for Independent Studies, St Leonards, NSW.
- Optimice. (2009) *ONA Surveys*. Sydney: Optimice Pty. Ltd.
- Palmer, C., Ziersch, A., Arthurson, K., & Baum, F. (2004) Challenging the stigma of public housing: preliminary findings from a qualitative study in South Australia. *Urban Policy and Research*, 22(4), 411-426.
- Pinkster, F. M. (2014) "I Just Live Here": Everyday Practices of Disaffiliation of Middle-class Households in Disadvantaged Neighbourhoods. *Urban Studies*, 51(4), 810-826.
- Putnam, R. D. (1993) The prosperous community. *The American Prospect*, 4(13), 35-42.

- Putnam, R. D. (2000) Bowling alone: America's declining social capital. *Culture and Politics* (pp. 223-234). Palgrave Macmillan US.
- Robertson, D., Smyth, J., & McIntosh, I. (2008) *Neighbourhood identity*. Research Report for Joseph Rowntree Foundation.
- Stevenson, C., McNamara, N., & Muldoon, O. (2014) Stigmatised Identity and Service Usage in Disadvantaged Communities: Residents', Community Workers' and Service Providers' Perspectives. *Journal of Community & Applied Social Psychology*, 24(6), 453-466.
- Touraine, A., & Macey, D. (2000) *Can we live together? Equality and difference*: Stanford University Press.
- Wacquant, L. (2007) Territorial Stigmatization in the Age of Advanced Marginality. *Thesis Eleven*, 91(1), 66-77.
- University of Tasmania Regional Urban Studies Laboratory (2016, forthcoming) *Brighton social mapping*. Research Report for Brighton Council.
- Vinson, T & Rawsthorne, M (2015) *Dropping off the edge 2015: Persistent communal disadvantage in Australia*. Final Report for Jesuit Social Services and Catholic Social Services Australia.
- Wacquant, L. (2014) Marginality, ethnicity and penalty in the neo-liberal city: an analytic cartography. *Ethnic and Racial Studies*, 37(10), 1687-1711.
- Wacquant, L., Slater, T., & Pereira, V. B. (2014) Territorial Stigmatization in Action. *Environment and Planning A*, 46(6), 1270-1280.
- Waltzer, M. (1990) *The civil society argument*. Gunnar Myrdal Lecture, University of Stockholm, October 1990.
- Warr, D. (2005a) There goes the neighbourhood: the malign effects of stigma. *Social City*, 19(3), 1-11.
- Warr, D. J. (2005b) Social networks in a 'discredited' neighbourhood. *Journal of Sociology*, 41(3), 285-308.
- Watt, P. (2006) Respectability, Roughness and 'Race': Neighbourhood Place Images and the Making of Working-Class Social Distinctions in London. *International Journal of Urban and Regional Research*, 30(4), 776-797.
- Waxman, C. (1983) *The Stigma of Poverty*, Elmsford, NY.
- Wood, M., Randolph, B. & Judd, B. (2002), *Resident participation, social cohesion and sustainability in neighbourhood renewal: developing best practice models*, AHURI Positioning Paper no.26. Australian Housing and Urban Research Institute.
- Woolcock, M., & Narayan, D. (2000) Social capital: Implications for development theory, research, and policy. *The world bank research observer*, 15(2), 225-249.

Zavaleta, D., Samuel, K., & Mills, C. (2014) *Social isolation: A conceptual and measurement proposal* (Vol. 67, p. 3). OPHI Working Papers.

Appendix 1

SNA measures used in report

Table 2: Average counts of ties in ego-networks by area

Table 1 was prepared by calculating the number of alters, the number of ties amongst those alters (both in total, meaning directed ties are included, and in non-directed form — unique alter-to-alter ties, with the latter calculated by dividing the total alter-to-alter ties by two) and the total ties (i.e. ego-to-alter plus non-directed or unique alter-to-alter ties), and then using these measures to generate a network density figure. In this case, network density is the total unique ties divided by the number of ego-to-alter ties. Averages for each area were then generated for each of measures, as well as overall averages for each measure.

Table 3: Average ego net measures by area

The measure of density shown in Table 2 is generated through UCINET, and is calculated differently from the density figure included in Table 1. In Table 2, density is defined as the actual number of directed ties among alters in the network divided by the total number of possible ties among alters. Thus 100 is the maximum possible density in a network. On this measure, P65's (Figure 3) network is denser than average, but not by such a large margin as before. By contrast, P12's (Figure 4) network still has an extremely low density because there are only two directed ties between his alters.

The other measures in Table 2 are measures of how the ego is positioned within their own social relationships. For example, a 'weak component' is a case where the ego is the only connection between otherwise disjointed sets of actors (i.e. A, B and C all know each other, and D, E and F all know each other, but the only connection between the two groups is that A and D both know the ego). A 'normalised' measure of weak components takes into account the size of the networks (i.e. a very large network can be expected to have some weak components, so the question becomes, is the number of weak components unexpected, given the size of the network?). The normalised measure is calculated by taking the number of weak components as a percentage of the number of alters in the network. It should be noted here that the measure is 'normal' in relative terms — there is no set percentage of weak components that is 'normal' applicable to all kinds of social networks. Thus the measure has to be assessed in relative terms within the network under analysis. In relative terms, the greater the number of alters for a given number of weak components, the smaller the normalised measure will be. According to this measure, P65's network has a much lower percentage of weak components than perhaps might be expected, given the size of her network, while P12's network has a very high proportion of weak components (as we can see from Figure 4).

'Broker' likewise captures the situation where the ego is the only link between two actors. It is calculated as the number of pairs of actors who do not have a direct connection, divided by two. The normalised figure takes into account the size of the network (the number of non-directional pairs in it, including the ego) and therefore assesses the extent to which the ego has the role of broker within the network, and therefore, how much influence they might have or how significant they might be to the way the network operates. The larger the network for a given number of brokerage opportunities for the ego, the smaller the normalised measure will be. The figures for the two comparison participants above indicate that P65, despite having a comparably large

network, has much less capacity to act as a broker because most of her named alters know each other and do not have to go through her. P12, on the other hand, is in most cases the only connection between his named alters, and therefore, his normalised broker measure is close to the maximum.

'Between-ness' refers to the number of all paths from actor to actor in the network that go via the ego — that is, how involved is the ego in their own network? It is calculated using a formula that accounts for situations when there are multiple options for the shortest path (i.e. actor A can get to actor C via ego or via actor D). A 'between-ness' measure is normalised by taking into account the maximum level of between-ness that would be possible (that is, how many paths would go via ego if the ego was the only point of contact between any of the alters?).

Table 4: Average ego net structural holes measures by area

The effective size of the network is calculated by averaging out the number of direct connections each alter has with other alters in the network (excluding ego) and then subtracting this average figure from the number of alters in the network. Thus in a network of ten alters, all of whom have a direct connection with every other alter, the effective size would be one, while in a network of ten alters, none of whom knew each other, the effective size would be the same as the number of alters (i.e. ten).

Constraint is premised on an assumption that ego is investing time and energy in maintaining relationships with alters to ego's own advantage, but that this investment might be counteracted by investment of time and energy by alters in each other. Therefore it is calculated using a formula that takes into account the number of alters in the ego's network and the number of direct connections each alter themselves has with the other alters. Constraint can be calculated in a way which takes into account differential investments of energy in different relationships, but in our data, which simply states that a tie exists or it doesn't, the assumption is that the ego invests equal amounts of time and energy in every relationship in which ego is involved, and likewise for alters.

Appendix 2

Expanded tables

Participant profile

Table P1: Participant sex by area

Area	Male		Female		Total
	No.	%	No.	%	No.
FB	6	23	20	77	26
PR	8	32	17	68	25
WG	6	23	20	77	26
GH	9	36	16	64	25
Total	29	28.4	73	71.6	102

Table P2: Participant age by area

Area	Age (years)								Total participants	Average age
	<20	20-29	30-39	40-49	50-59	60-69	70-79	80+		
FB	0	0	2	5	1	11	6	1	26	59.93
PR	0	2	4	5	8	3	1	2	25	50.6
WG	0	4	7	5	5	4	1	0	26	45.5
GH	0	7	3	8	4	3	0	0	25	41.44
Total (%)	0	12.7	15.7	22.5	17.6	20.6	7.8	2.9	102	

Table P3: Household composition by area

Area	Household type							Dependents	
	Single	Couple	Couple and dependent s	Single Parent	Extended Family	Shared housing	Other	None	One or more
FB	13	5	4	3	1	0	0	21	5
PR	8	2	5	8	1	0	1	14	11
WG	7	2	6	5	1	2	3	15	11
GH	4	1	7	11	1	0	1	9	16
Total (%)	32	10	22	27	4	2	4	59	43

Table P4: Work hours by area

Area	No work	Over 35 hours a week	Under 35 hours a week
FB	23	0	3
PR	22	1	2
WG	18	1	7
GH	23	0	2

Total	86	2	14
--------------	-----------	----------	-----------

Table P5: Source of income by area

Area	No Centrelink payment	Centrelink payment type						
		Parenting Payment		Newstart Allowance	Youth Allowance	Age Pension	Disability Support Pension	Other
		Partnered	Single					
FB	2	1	1	1	0	7	9	5
PR	0	0	3	3	0	2	12	5
WG	4	2	4	3	0	3	7	3
GH	0	3	3	9	0	1	7	2
Total	6	6	11	16	0	13	34	15

Table P6: Housing Tenure by area

Area	Owner		Renting				Other
	No mortgage	Mortgage	Housing Tasmania	Community housing provider	Real estate agent	Private landlord	
FB	4	3	0	18	0	1	0
PR	1	2	2	19	0	1	0
WG	2	4	2	15	2	1	0
GH	1	2	3	11	1	6	1
Total	8	11	7	62	3	9	1

Table P7: Highest level of education by area

Area	Less than Year 10	Year 10	Year 11-12	TAFE/VET	Associate diploma	Tertiary (undergraduate)	Tertiary (postgraduate)
FB	12	3	5	4	0	2	0
PR	7	9	4	4	0	1	0
WG	3	8	6	7	1	1	0
GH	4	11	1	7	1	0	1
TOTAL (n.)	26	31	16	22	2	4	1

Table P8: Length of time living in current house by area

Area	Time in years							Whole life
	Less than 0.5	0.5 to 1	1 to 3	3 to 5	5 to 10	10 plus		
FB	2	3	4	2	2	13	0	
PR	0	2	3	2	4	14	0	
WG	2	0	2	2	5	15	0	
GH	3	3	4	7	3	5	0	

Total (n.)	7	8	13	13	14	47	0
-------------------	----------	----------	-----------	-----------	-----------	-----------	----------

Table P9: Length of time living in neighbourhood by area

Area	Time in years						Whole life
	Less than 0.5	0.5 to 1	1 to 3	3 to 5	5 to 10	10 plus	
FB	1	2	0	3	2	17	1
PR	0	2	2	0	1	18	2
WG	1	0	1	0	3	19	2
GH	2	3	2	1	6	7	4
Total (n.)	4	7	5	4	12	61	9

Neighbourhood stigma

Table S1: Agreement with statements about the neighbourhood, by area

Area	Extent of agreement with statement (averages derived from five point scale where 1=strongly agree, 5=strongly disagree)			Are there people in the community who are isolated and don't take part in community events?
	Most people in this neighbourhood will help me if I need it	In this neighbourhood, I have to be alert or people will take advantage of me	The way outsiders see the area has a big effect on people living here	% of participants who said 'yes'
FB	2.23	2.96	2.00	65.4
PR	2.36	3.20	2.08	60.0
WG*	2.12	3.08	1.64	80.0
GH*	2.29	2.67	2.54	70.8
Overall	2.25	2.98	2.06	69.0

*Data was missing for one participant in each of these areas (excluded from analysis).

Table S2: Satisfaction with various life domains, by area

Area	Level of satisfaction (averages derived from five point scale where 1=very satisfied, 5=very dissatisfied)					
	Condition of housing	Safety of neighbourhood	Own physical health	Own mental health	Choice and control over life	Life overall
FB	1.46	2.04	2.31	1.81	1.50	1.85
PR	2.68	3.04	2.76	2.24	1.84	2.08
WG	1.96	2.56	2.84	2.12	1.80	1.92
GH	2.38	2.71	2.79	2.13	2.13	2.04
All areas	2.11	2.58	2.67	2.07	1.81	1.97

Table S3: Perception of problems in the area, by area (B)

Area	% perceiving issue to be a problem (major or minor) – all issues
FB	27.25
PR	42.33
WG	49.08
GH	45.00

Table S4: Perception of problems in the area, by area (A)

Problem	FB			PR			WG*			GH			All areas		
	0=Not a problem, 1=Minor problem, 2=Major problem														
	0	1	2	0	1	2	0	1	2	0	1	2	0	1	2
Rubbish and general appearance	14	9	3	9	10	6	8	16	2	9	8	8	41	44	19
Abandoned and burnt out vehicles	18	2	6	12	7	6	10	3	12	8	8	9	48	20	31
Noisy neighbours	21	3	2	14	7	4	12	11	2	11	8	6	58	29	14
Lack of unity between people	16	6	4	11	9	5	10	10	5	13	6	6	50	32	20
Pets and animals	20	3	3	19	2	4	14	8	3	18	3	4	71	16	14
Children and youth	20	3	3	15	5	5	11	9	5	13	7	5	59	24	18
Public transport	20	4	2	18	7	0	10	7	8	14	3	8	62	22	18
Racial or other harassment	25	0	1	20	3	2	20	3	2	20	3	2	85	9	6
Drunk or rowdy behaviour	19	3	4	15	8	2	15	7	3	14	6	5	62	24	14
Vandalism	17	5	4	12	6	7	11	6	8	11	7	7	51	24	26
Damage to property	20	3	3	18	5	2	17	6	2	16	7	2	71	21	9
Drug use or dealing	17	4	5	13	2	10	11	4	10	18	2	5	59	12	30

*Data for this question was missing for one participant in this area.

Table S5: Things participants disliked about their area (open-ended, post-coded), by area

Dislike	Number of participants identifying this issue				
	FB	PR	WG	GH	Total
Negative and disruptive behaviour	3	13	8	11	33
Motocross bikes or unregistered vehicles	1	7	7	10	25
Negative area appearance	6	5	5	6	22
Drug problems	3	6	5	4	18
Other	7	2	3	3	15
Stigma	4	2	5	3	14
Public transport	0	2	4	6	12
Lack of safety	0	1	5	6	12
Lack of services and amenities for youth	2	1	6	0	9
More/better services needed	3	1	0	3	7
Isolation	0	1	3	1	4
Poor parenting	1	0	0	2	3
Relationship problems	0	0	0	2	2
No dislikes	3	3	1	1	8

Table S6: Experience of indicators of housing instability within the last five years by area

INDICATOR	FB					PR					WG*					GH				
	Number of times																			
	0	1	2	3	3+	0	1	2	3	3+	0	1	2	3	3+	0	1	2	3	3+
Homeless	25	1	0	0	0	21	3	0	1	0	25	0	1	0	0	19	4	1	0	1

Notice vacate	26	0	0	0	0	22	3	0	0	0	25	1	0	0	0	22	3	0	0	0
Eviction	26	0	0	0	0	23	1	0	1	0	26	0	0	0	0	24	0	1	0	0

Relationships

Table R1: Participants' estimate of how many people they know in and out of the neighbourhood, by area

Number of people known	FB		PR		WG		GH		Total	
	In	Out	In	Out	In	Out	In	Out	In	Out
None	0	1	0	2	0	0	0	0	3	3
1-2	2	1	0	0	0	0	1	1	5	2
3-4	0	0	2	2	0	2	3	1	1	5
5-9	3	2	6	4	4	2	4	2	17	10
10-19	9	7	2	4	6	3	4	7	21	21
20-50	5	7	8	7	9	11	8	6	30	31
50+	7	8	7	6	7	8	5	8	26	30
Total	26	26	25	25	26	26	25	25	102	102
Average number of minimum ties	21.4	23.9	22.6	20.2	23.5	25.6	19.2	24.2	21.7	23.5

Table R2: Extent of participants' agreement with the statement 'The people closest to me live in this neighbourhood', by area

Area	Response scale				
	Strongly Agree	Agree	Neutral	Disagree	Strongly Disagree
FB	14	6	1	4	1
PR	9	9	3	3	1
WG	12	2	2	7	3
GH	14	3	1	2	5
All areas	49	20	7	16	10

Table R3: Bridging social capital ties – type of relationship, by area

Type of relationship	FB		PR		WG		GH		All areas	
	No.	%	No.	%	No.	%	No.	%	No.	%
Don't know this person	1	3.6	0	0.0	0	0.0	0	0.0	1	1.0
Immediate family	4	14.3	5	27.8	1	3.8	4	14.8	14	14.1
Wider family	1	3.6	1	5.6	1	3.8	4	14.8	7	7.1
Family friend	0	0.0	0	0.0	0	0.0	2	7.4	2	2.0
Close friend	5	17.9	1	5.6	3	11.5	5	18.5	14	14.1
Friend	6	21.4	2	11.1	7	26.9	2	7.4	17	17.2
Neighbour	2	7.1	1	5.6	0	0.0	1	3.7	4	4.0
Colleague	0	0.0	0	0.0	4	15.4	0	0.0	4	4.0
Acquaintance	4	14.3	2	11.1	2	7.7	0	0.0	8	8.1
Service provider	3	10.7	5	27.8	2	7.7	9	33.3	19	19.2
Unsure	1	3.6	1	5.6	2	7.7	0	0.0	4	4.0

Other	1	3.6	0	0.0	4	15.4	0	0.0	5	5.1
Total number of ties	27	100.0	18	100.0	26	100.0	27	100.0	98	100.0

Table R4: Ego > alter relationships, ties out and in by location (collated by origin location), all name generators

Location combination (ego > alter)		Number of ties	Percentage of ties
FB	FB	42	22.5
FB	PR	20	10.7
FB	WG	11	5.9
FB	GH	1	0.5
FB	Outside	98	52.4
FB	Unknown	15	8.0
Total FB >		187	100.0
PR	FB	23	15.1
PR	PR	33	21.7
PR	WG	9	5.9
PR	GH	5	3.3
PR	Outside	57	37.5
PR	Unknown	25	16.4
Total PR >		152	100.0
WG	FB	7	4.1
WG	PR	3	1.8
WG	WG	57	33.3
WG	GH	8	4.7
WG	Outside	85	49.7
WG	Unknown	11	6.4
Total WG >		171	100.0
GH	FB	10	7.2
GH	PR	8	5.8
GH	WG	8	5.8
GH	GH	36	25.9
GH	Outside	68	48.9
GH	Unknown	9	6.5
Total GH >		139	100.0
TOTAL		649	

Table R5: Volunteering activities (open-ended, post-coded), by area

Type of volunteering	Number of participants				
	FB	PR	WG	GH	Total
General assistance	15	10	14	11	50
Driving for/with others	4	9	14	8	35
Carer	9	8	6	7	32
None	6	5	3	4	16
Peer support	3	3	2	2	10
Financial help	2	0	3	1	6
Housing others	0	0	1	1	2
Volunteering for an organisation	3	3	4	4	14
Total	42	38	47	38	165

Table R6: Ego > alter relationships, ties out and in by location (collated by destination location), all name generators

Location combination (ego > alter)		Number of ties	Percentage of ties
FB	FB	42	51.2
PR	FB	23	28.0
WG	FB	7	8.5
GH	FB	10	12.2
Total > FB		82	100.0
FB	PR	20	31.3
PR	PR	33	51.6
WG	PR	3	4.7
GH	PR	8	12.5
Total > PR		64	100.0
FB	WG	11	12.9
PR	WG	9	10.6
WG	WG	57	67.1
GH	WG	8	9.4
Total > WG		85	100.0
FB	GH	1	2.0
PR	GH	5	10.0
WG	GH	8	16.0
GH	GH	36	72.0
Total > GH		50	100.0
FB	Outside	98	31.8
PR	Outside	57	18.5
WG	Outside	85	27.6
GH	Outside	68	22.1
Total > Outside		308	100.0
FB	Unknown	15	25.0
PR	Unknown	25	41.7
WG	Unknown	11	18.3
GH	Unknown	9	15.0
Total > Unknown		60	100.0
TOTAL		649	

Table R7: All relationships, ties out and in by location (collated by origin location), all name generators

Location combination (ego > alter)		Number of ties	Percentage of ties
FB	FB	134	25.2
FB	PR	58	10.9
FB	WG	50	9.4
FB	GH	7	1.3
FB	Outside	259	48.7
FB	Unknown	24	4.5
Total FB >		532	100.0
PR	FB	61	13.9
PR	PR	97	22.0
PR	WG	35	8.0
PR	GH	18	4.1
PR	Outside	196	44.5
PR	Unknown	33	7.5
Total PR >		440	100.0
WG	FB	47	8.5
WG	PR	33	6.0
WG	WG	167	30.3
WG	GH	33	6.0
WG	Outside	250	45.4
WG	Unknown	21	3.8
Total WG >		551	100.0
GH	FB	16	5.0
GH	PR	25	7.8
GH	WG	34	10.6
GH	GH	107	33.4
GH	Outside	127	39.7
GH	Unknown	11	3.4
Total GH >		320	100.0
Outside	FB	153	11.0
Outside	PR	134	9.6
Outside	WG	162	11.6
Outside	GH	45	3.2
Outside	Outside	886	63.5
Outside	Unknown	16	1.1
Total Outside >		1396	100.0
Unknown	FB	14	14.0
Unknown	PR	15	15.0
Unknown	WG	13	13.0
Unknown	GH	3	3.0
Unknown	Outside	28	28.0
Unknown	Unknown	27	27.0
Total Unknown >		100	100.0
TOTAL		3339	

Table R8: All ego > ties, by social capital type, by location (detailed)

Location combination (ego > alter)		Influencing change	Help with tasks	Ask for \$20	Socialising	Personal worries	Important decision	Good leaders	Especially close
FB	FB	4	9	18	25	10	9	2	1
FB	PR	2	4	9	11	5	5	1	2
FB	WG	3	0	4	7	2	1	2	0
FB	GH	0	1	1	0	0	0	0	0
FB	Outside	8	15	18	29	19	25	9	29
FB	Unknown	0	3	0	0	8	1	1	0
Total FB >		17	32	50	72	44	41	15	32
PR	FB	2	4	8	13	3	2	1	0
PR	PR	0	5	16	15	7	4	2	2
PR	WG	0	3	3	2	3	2	1	1
PR	GH	0	1	4	3	1	1	1	0
PR	Outside	1	14	17	23	20	12	2	8
PR	Unknown	4	4	0	1	8	1	4	0
Total PR >		7	31	48	57	42	22	11	11
WG	FB	0	2	4	3	1	2	0	0
WG	PR	0	0	2	4	0	2	0	0
WG	WG	6	7	25	22	16	10	8	1
WG	GH	0	2	4	1	2	3	0	2
WG	Outside	3	13	25	41	30	26	7	15
WG	Unknown	3	2	0	0	0	1	4	0
Total WG >		12	26	60	71	49	44	19	18
GH	FB	3	7	6	3	0	2	0	0
GH	PR	1	2	1	7	2	2	0	0
GH	WG	1	4	3	5	1	1	3	0
GH	GH	2	11	13	21	13	15	4	1
GH	Outside	3	7	21	33	22	23	5	12
GH	Unknown	1	0	0	0	2	0	5	0
Total GH >		11	31	44	69	40	43	17	13
TOTAL		47	120	202	269	175	150	62	74

Table R9: Forest Bay – closeness of ties, by social capital type

Closeness	Bridging		Bonding		Help with tasks		Ask for \$20		All types of social capital	
	No.	%	No.	%	No.	%	No.	%	No.	%
Don't know them	1	3.6	9	6.5	2	6.3	2	4.0	11	5.9
Very close	7	25.0	95	68.8	21	65.6	40	80.0	113	61.1
Somewhat close	8	28.6	19	13.8	4	12.5	7	14.0	30	16.2
Not sure	1	3.6	0	0.0	0	0.0	0	0.0	1	0.5
Not so close	7	25.0	11	8.0	4	12.5	1	2.0	21	11.4
Not close at all	4	14.3	4	2.9	1	3.1	0	0.0	9	4.9
Total	28	100.	138	100.	32	100.	50	100.	185	100.

		0		0		0		0		0
--	--	---	--	---	--	---	--	---	--	---

Table R10: Characteristics of alters living outside the area compared to other alters (all name generators)

Characteristic	Alters living outside the area		Other alters	
	No.	%	No.	%
Total number of ties	335	100.0	344	100.0
Type of relationship				
Don't know them	6	1.8	6	1.7
Immediate family	124	37.0	94	27.3
Wider family	43	12.8	41	11.9
Family friend	17	5.1	8	2.3
Close friend	69	20.6	46	13.4
Friend	49	14.6	46	13.4
Neighbour	0	0.0	37	10.8
Colleague	5	1.0	7	2.0
Acquaintance	4	1.2	11	3.2
Service Provider	13	3.9	42	12.2
Unsure	3	0.9	2	0.6
Other	2	0.6	4	1.2
Length of relationship				
Don't know them	9	2.7	12	3.5
Less than one year	8	2.4	20	5.8
One to three years	22	6.6	40	11.6
Three to five years	26	7.8	28	8.1
Five to ten years	39	11.6	37	10.8
Ten to twenty years	36	10.7	61	17.7
Twenty plus years	195	58.2	146	42.4
Closeness				
Don't know them	6	1.8	6	1.7
Very close	218	65.1	169	49.1
Somewhat close	80	23.9	96	27.9
Not sure	4	1.2	11	3.2
Not so close	19	5.7	38	1.1
Not close at all	8	2.4	24	7.0
Average closeness*	1.5		1.9	
Main form of contact				
Don't contact	4	1.2	13	3.8
Face to face	149	44.5	247	71.8
Telephone	117	34.9	45	13.1
SMS	29	8.7	11	3.2
Email	2	0.6	1	0.3
Social media	19	5.7	9	2.6
Letter	0	0.0	2	0.6
Haven't recently	5	1.5	11	3.2
Other	4	1.2	5	1.5
*Derived from a five point scale where 1=very close and 5=not close at all.				

Table R11: 'Helping with tasks' ties – relationship characteristics, by area

Characteristic	FB		PR		WG		GH		All areas	
	No.	%	No.	%	No.	%	No.	%	No.	%
Total number of ties	32	100.0	31	100.0	26	100.0	31	100.0	120	100.0
Type of relationship										
Don't know them	17	53.1	11	35.5	7	21.2	9	29.0	44	34.6
Immediate family	4	12.5	3	9.7	9	27.3	3	9.7	19	15.0
Wider family	1	3.1	3	9.7	2	6.1	0	0.0	6	4.7
Family friend	0	0.0	1	3.2	3	9.1	9	29.0	13	10.2
Close friend	0	0.0	3	9.7	1	3.0	3	9.7	7	5.5
Friend	2	6.3	3	9.7	2	6.1	4	12.9	11	8.7
Neighbour	0	0.0	0	0.0	0	0.0	0	0.0	0	0.0
Colleague	1	3.1	1	3.2	0	0.0	0	0.0	2	1.6
Acquaintance	5	15.6	5	16.1	9	27.3	3	9.7	22	17.3
Service Provider	0	0.0	1	3.2	0	0.0	0	0.0	1	0.8
Unsure	0	0.0	0	0.0	0	0.0	0	0.0	0	0.0
Other	17	53.1	11	35.5	7	21.2	9	29.0	44	34.6
Length of relationship										
Don't know them	2	6.3	2	6.5	2	7.7	0	0.0	6	5.0
Less than one year	1	3.1	4	12.9	0	0.0	4	12.9	9	7.5
One to three years	3	9.4	3	9.7	1	3.8	3	9.7	10	8.3
Three to five years	3	9.4	5	16.1	0	0.0	4	12.9	12	10.0
Five to ten years	1	3.1	4	12.9	2	7.7	3	9.7	10	8.3
Ten to twenty years	3	9.4	3	9.7	7	26.9	1	3.2	14	11.7
Twenty plus years	19	59.4	10	32.3	14	53.8	16	51.6	59	49.2
Closeness										
Don't know them	2	6.3	0	0.0	0	0.0	0	0.0	2	1.7
Very close	21	65.6	17	54.8	13	50.0	21	67.7	72	60.0
Somewhat close	4	12.5	5	16.1	8	30.8	6	19.4	23	19.2
Not sure	0	0.0	1	3.2	1	3.8	0	0.0	2	1.7
Not so close	4	12.5	2	6.5	2	7.7	4	12.9	12	10.0
Not close at all	1	3.1	6	19.4	2	7.7	0	0.0	9	7.5
Main form of contact										
Don't contact	4	12.5	0	0.0	1	3.8	0	0.0	5	4.2
Face to face	23	71.9	20	64.5	18	69.2	21	67.7	82	68.3
Telephone	3	9.4	4	12.9	6	23.1	7	22.6	20	16.7
SMS	2	6.3	4	12.9	0	0.0	3	9.7	9	7.5
Email	0	0.0	0	0.0	0	0.0	0	0.0	0	0.0
Social media	0	0.0	0	0.0	1	3.8	0	0.0	1	0.8
Letter	0	0.0	1	3.2	0	0.0	0	0.0	1	0.8
Haven't recently	0	0.0	0	0.0	0	0.0	0	0.0	0	0.0
Other	0	0.0	2	6.5	0	0.0	0	0.0	2	1.7

Table R12: 'Ask for \$20' ties – relationship characteristics, by area

Characteristic	FB		PR		WG		GH		All areas	
	No.	%	No.	%	No.	%	No.	%	No.	%
Total number of ties	50	100	48	100.0	60	100.0	44	100.0	202	100.0
Type of relationship										
Don't know them	2	4.0	0	0.0	0	0.0	0	0.0	2	1.0
Immediate family	27	54.0	25	52.1	33	55.0	17	38.6	102	50.5
Wider family	5	10.0	5	10.4	10	16.7	5	11.4	25	12.4
Family friend	0	0.0	4	8.3	10	16.7	2	4.5	16	7.9
Close friend	10	20.0	4	8.3	7	11.7	11	25.0	32	15.8
Friend	3	6.0	6	12.5	0	0.0	4	9.1	13	6.4
Neighbour	3	6.0	4	8.3	0	0.0	5	11.4	12	5.9
Colleague	0	0.0	0	0.0	0	0.0	0	0.0	0	0.0
Acquaintance	0	0.0	0	0.0	0	0.0	0	0.0	0	0.0
Service Provider	0	0.0	0	0.0	0	0.0	0	0.0	0	0.0
Unsure	0	0.0	0	0.0	0	0.0	0	0.0	0	0.0
Other	0	0.0	0	0.0	0	0.0	0	0.0	0	0.0
Length of relationship										
Don't know them	1	2.0	1	2.1	0	0.0	2	4.5	4	2.0
Less than one year	3	6.0	1	2.1	0	0.0	3	6.8	7	3.5
One to three years	1	2.0	3	6.3	0	0.0	4	9.1	8	4.0
Three to five years	2	4.0	6	12.5	6	10.0	6	16.6	20	9.9
Five to ten years	3	6.0	4	8.3	12	20.0	7	15.9	26	12.9
Ten to twenty years	38	76.0	33	68.8	42	70.0	22	50.0	135	66.8
Twenty plus years	1	2.0	1	2.1	0	0.0	2	4.5	4	2.0
Closeness										
Don't know them	2	4.0	0	0.0	0	0.0	0	0.0	2	1.0
Very close	40	80.0	35	72.9	44	73.3	33	75.0	152	75.2
Somewhat close	7	14.0	12	25.0	13	21.7	8	18.2	40	19.8
Not sure	0	0.0	1	2.1	0	0.0	1	2.3	2	1.0
Not so close	1	2.0	0	0.0	3	5.0	2	4.5	6	3.0
Not close at all	0	0.0	0	0.0	0	0.0	0	0.0	0	0.0
Main form of contact										
Don't contact	2	4.0	0	0.0	0	0.0	0	0.0	2	1.0
Face to face	36	72.0	32	66.7	47	78.3	23	52.3	138	68.3
Telephone	12	24.0	10	20.8	13	21.7	9	20.5	44	21.8
SMS	0	0.0	3	6.3	0	0.0	10	22.7	13	6.4
Email	0	0.0	0	0.0	0	0.0	0	0.0	0	0.0
Social media	0	0.0	2	4.2	0	0.0	2	4.5	4	2.0
Letter	0	0.0	0	0.0	0	0.0	0	0.0	0	0.0
Haven't recently	0	0.0	1	2.1	0	0.0	0	0.0	1	0.5
Other	0	0.0	0	0.0	0	0.0	0	0.0	0	0.0

Table R13: Woodland Grove – relationship characteristics, by social capital type

Characteristic	Bridging		Bonding		Help tasks with		Ask for \$20		All social capital		
	No.	%	No.	%	No.	%	No.	%	No.	%	
Total number of ties	26	100.0	119	100.0	26	100.0	60	100.0	168	100.0	
Type of relationship											
Don't know them	0	0.0	0	0.0	0	0.0	0	0.0	0	0.0	
Immediate family	1	3.8	54	45.4	7	21.2	33	55.0	58	34.5	
Wider family	1	3.8	19	16.0	9	27.3	10	16.7	33	19.6	
Family friend	0	0.0	1	0.8	2	6.1	10	16.7	2	1.2	
Close friend	3	11.5	29	24.4	3	9.1	7	11.7	31	18.5	
Friend	7	26.9	11	9.2	1	3.0	0	0.0	16	9.5	
Neighbour	0	0.0	2	1.7	2	6.1	0	0.0	10	6.0	
Colleague	4	15.4	1	0.8	0	0.0	0	0.0	4	2.4	
Acquaintance	2	7.7	0	0.0	0	0.0	0	0.0	2	1.2	
Service Provider	2	7.7	2	1.7	9	27.3	0	0.0	6	3.6	
Unsure	2	7.7	0	0.0	0	0.0	0	0.0	2	1.2	
Other	4	15.4	0	0.0	0	0.0	0	0.0	4	2.4	
Length of relationship											
Don't know them	0	0.0	0	0.0	2	7.7	0	0.0	2	1.2	
Less than one year	1	3.8	2	1.7	0	0.0	0	0.0	3	1.8	
One to three years	4	15.4	1	0.8	1	3.8	0	0.0	6	3.6	
Three to five years	1	3.8	2	1.7	0	0.0	0	0.0	3	1.8	
Five to ten years	5	19.2	10	8.4	2	7.7	6	10.0	19	11.3	
Ten to twenty years	7	26.9	27	22.7	7	26.9	12	20.0	39	23.2	
Twenty plus years	8	30.8	77	64.7	14	53.8	42	70.0	96	57.1	
Closeness											
Don't know them	0	0.0	0	0.0	0	0.0	0	0.0	0	0.0	
Very close	5	19.2	87	73.1	13	50.0	44	73.3	98	58.3	
Somewhat close	5	19.2	27	22.7	8	30.8	13	21.7	44	26.2	
Not sure	1	3.8	1	0.8	1	3.8	0	0.0	2	1.2	
Not so close	9	34.6	3	2.5	2	7.7	3	5.0	15	8.9	
Not close at all	6	23.1	1	0.8	2	7.7	0	0.0	9	5.4	
Average closeness*	3.2		1.4		1.9		1.4		1.7		
Main form of contact											
Don't contact	1	3.8	0	0.0	1	3.8	0	0.0	2	1.2	
Face to face	9	34.6	81	68.1	18	69.2	47	78.3	108	64.3	
Telephone	5	19.2	33	27.7	6	23.1	13	21.7	41	24.4	
SMS	0	0.0	0	0.0	0	0.0	0	0.0	0	0.0	
Email	0	0.0	0	0.0	0	0.0	0	0.0	0	0.0	
Social media	2	7.7	4	3.4	1	3.8	0	0.0	7	4.2	
Letter	0	0.0	0	0.0	0	0.0	0	0.0	0	0.0	
Haven't recently	8	30.8	0	0.0	0	0.0	0	0.0	8	4.8	
Other	1	3.8	1	0.8	0	0.0	0	0.0	2	1.2	

*Derived from a five point scale where 1=very close and 5=not close at all.

Table R14: Grass Hill – relationship characteristics, by social capital type

Characteristic	Bridging		Bonding		Help with tasks		Ask for \$20		All types of social capital		
	No.	%	No.	%	No.	%	No.	%	No.	%	
Total number of ties											
Type of relationship											
Don't know them	0	0.0	0	0.0	0	0.0	0	0.0	0	0.0	
Immediate family	4	14.8	31	31.0	9	29.0	17	38.6	41	30.6	
Wider family	4	14.8	9	9.0	3	9.7	5	11.4	13	9.7	
Family friend	2	7.4	5	5.0	0	0.0	2	4.5	6	4.5	
Close friend	5	18.5	28	28.0	9	29.0	11	25.0	31	23.1	
Friend	2	7.4	15	15.0	3	9.7	4	9.1	17	12.7	
Neighbour	1	3.7	7	7.0	4	12.9	5	11.4	11	8.2	
Colleague	0	0.0	0	0.0	0	0.0	0	0.0	0	0.0	
Acquaintance	0	0.0	0	0.0	0	0.0	0	0.0	0	0.0	
Service Provider	9	33.3	4	4.0	3	9.7	0	0.0	14	10.4	
Unsure	0	0.0	0	0.0	0	0.0	0	0.0	0	0.0	
Other	0	0.0	1	1.0	0	0.0	0	0.0	1	0.7	
Length of relationship											
Don't know them	2	7.4	0	0.0	0	0.0	0	0.0	2	1.5	
Less than one year	1	3.7	3	3.0	4	12.9	2	4.5	6	4.5	
One to three years	2	7.4	12	12.0	3	9.7	3	6.8	14	10.4	
Three to five years	5	18.5	10	10.0	4	12.9	4	9.1	14	10.4	
Five to ten years	4	14.8	12	12.0	3	9.7	6	16.6	17	12.7	
Ten to twenty years	2	7.4	13	13.0	1	3.2	7	15.9	18	13.4	
Twenty plus years	11	40.7	50	50.0	16	51.6	22	50.0	63	47.0	
Closeness											
Don't know them	0	0.0	0	0.0	0	0.0	0	0.0	0	0.0	
Very close	15	55.6	71	71.0	21	67.7	33	75.0	83	61.9	
Somewhat close	5	18.5	23	23.0	6	19.4	8	18.2	33	24.6	
Not sure	1	3.7	3	3.0	0	0.0	1	2.3	5	3.7	
Not so close	2	7.4	1	1.0	4	12.9	2	4.5	7	5.2	
Not close at all	4	14.8	2	2.0	0	0.0	0	0.0	6	4.5	
Main form of contact											
Don't contact	3	11.1	0	0.0	0	0.0	0	0.0	3	2.2	
Face to face	13	48.1	44	44.0	21	67.7	23	52.3	61	45.5	
Telephone	8	29.6	26	26.0	7	22.6	9	20.5	34	25.4	
SMS	1	3.7	23	23.0	3	9.7	10	22.7	26	19.4	
Email	0	0.0	1	1.0	0	0.0	0	0.0	1	0.7	
Social media	2	7.4	5	5.0	0	0.0	2	4.5	8	6.0	
Letter	0	0.0	0	0.0	0	0.0	0	0.0	0	0.0	
Haven't recently	0	0.0	0	0.0	0	0.0	0	0.0	0	0.0	
Other	0	0.0	1	1.0	0	0.0	0	0.0	1	0.7	

Connections to services

Table C1: Take up of local services, by area (n)

Service type	FB n=26			PR n=25			WG n=25**			GH n=25		
	Use	Don't need	Don't use*	Use	Don't need	Don't use*	Use	Don't need	Don't use*	Use	Don't need	Don't use*
Aboriginal	2	23	1	5	19	1	3	21	1	3	22	0
Abuse & assault	0	26	0	0	23	2	0	25	0	2	22	1
Education	3	23	0	3	20	2	3	20	2	8	13	4
Employment	4	21	1	4	20	1	6	16	3	5	17	3
Emergency relief	3	22	1	8	17	0	6	19	0	9	15	1
Financial help	1	25	0	3	22	0	4	21	0	3	21	1
Gambling	0	26	0	1	24	0	0	25	0	0	25	0
Legal & advocacy	2	23	1	5	15	5	2	21	2	5	19	1
Medical	8	8	10	14	1	10	13	3	9	9	7	9
Mental health	3	23	0	2	21	2	5	20	0	6	18	1
Migrant	0	26	0	0	25	0	0	25	0	0	25	0
Sporting clubs	1	25	1	2	22	1	3	22	0	3	21	1
Housing	13	13	0	15	7	3	13	10	2	12	11	2
Support & self help	2	24	0	0	25	0	1	24	0	1	22	2
Alcohol & drugs	0	24	1	4	21	0	0	24	1	0	25	0
Local government	11	14	1	16	9	0	17	8	0	8	14	3
Children's	3	23	0	4	21	0	3	22	0	2	21	2
Religious	0	26	0	1	24	0	1	24	0	1	23	1
Library, PCYC etc.	13	12	1	13	9	3	15	10	0	12	13	0
General welfare	3	22	1	6	18	1	7	18	0	6	17	2
Counselling	3	23	0	5	19	1	4	20	1	4	20	1

**Don't use' includes the following options: hard to access, staff are unfriendly, don't provide what I need, 'other'.

**Data for this question was missing for one participant in this area, so she was excluded from analysis.

Table C2: Interest in additional services and support, by area

Service type	FB n=26			PR n=25			WG n=25*			GH n=25		
	No	Yes	I do	No	Yes	I do	No	Yes	I do	No	Yes	I do
Education & training	17	7	2	13	10	2	8	14	3	7	16	2
Finding employment	18	7	1	15	7	3	11	12	2	13	10	2
Leisure activities	17	9	0	9	14	2	9	16	0	7	18	0
Managing money	21	5	0	19	2	4	18	7	0	16	7	2
Filling in forms	19	7	0	19	6	0	22	3	0	18	7	0
Legal issues	16	7	3	14	4	7	14	10	1	11	11	3
Parenting skills	23	2	1	23	2	0	22	3	0	21	2	2
Household management skills	22	2	2	25	0	0	22	3	0	19	5	1
Using fewer drugs and/or alcohol	25	0	1	21	1	3	23	2	0	24	1	0
Reducing or quitting smoking	19	5	2	19	2	4	15	10	0	9	15	1

Making friends	23	3	0	19	6	0	14	9	2	16	9	0
Average	20.0	4.9	1.1	17.8	4.9	2.3	16.2	8.1	0.7	14.6	9.2	1.2
*Data for this question was missing for one participant in this area, so she was excluded from analysis.												